

User Requirements Specification for the MCS

WP6. Development and implementation of
the furnace monitoring and control system

(M&CS)

DELIVERABLE

6.1

VULKANO
Novel integrated
refurbishment solution
as a key path towards creating
eco-efficient and competitive furnaces

From July 2016 to December 2019

Grant agreement
723803


Date: 25/05/2017

Prepared by: TECNALIA



This project has received funding from the European Union's
Horizon 2020 research and innovation programme
under grant agreement No 723803

VULKANO
LEADING THE CHANGE TOWARDS
ECO-EFFICIENT FURNACES

	Document:	D6.1 User Requirements Specification for the MCS		
	Author:	Tecnalía	Version:	2
	Reference:	D6.1 VULKANO G.A. 723803	Date:	25/05/17


DELIVERABLE FACTSHEET

Document Name: Deliverable 6.1. User Requirements Specification for the M&CS
Responsible Partner: TECNALIA
WP: 6. Development and implementation of the furnace monitoring and control system
Task: 6.1 User Requirements Specification for the M&CS
Deliverable nº: 6.1
Version: 2
Version Date: 25.05.2017

DISSEMINATION LEVEL	
X	PU = Public
	PP = Restricted to other programme participants (including the EC)
	RE = Restricted to a group specified by the consortium (including the EC)
	CO = Confidential, only for members of the consortium (including the EC)

Approvals

Author/s	Company TECNALIA
Reviewers	CIRCE
Contributor/s	TORRECID VALJI ASAS

	Document:	D6.1 User Requirements Specification for the MCS	
	Author:	Tecnalía	Version: 2
	Reference:	D6.1 VULKANO G.A. 723803	Date: 25/05/17


DISCLAIMER OF WARRANTIES

“This project has received funding from the European Union’s Horizon 2020 research and innovation programme under Grant Agreement No 723803”.”

This document has been prepared by VULKANO project partners as an account of work carried out within the framework of the EC-GA contract no 723803.

Neither Project Coordinator, nor any signatory party of VULKANO Project Consortium Agreement, nor any person acting on behalf of any of them:

- (a) makes any warranty or representation whatsoever, express or implied,
 - (i). with respect to the use of any information, apparatus, method, process, or similar item disclosed in this document, including merchantability and fitness for a particular purpose, or
 - (ii). that such use does not infringe on or interfere with privately owned rights, including any party's intellectual property, or
 - (iii). that this document is suitable to any particular user's circumstance; or
- (b) assumes responsibility for any damages or other liability whatsoever (including any consequential damages, even if Project Coordinator or any representative of a signatory party of the VULKANO Project Consortium Agreement, has been advised of the possibility of such damages) resulting from your selection or use of this document or any information, apparatus, method, process, or similar item disclosed in this document.

	Document:	D6.1 User Requirements Specification for the MCS	
	Author:	Tecnia	Version: 2
	Reference:	D6.1 VULKANO G.A. 723803	Date: 25/05/17

ABBREVIATIONS

EHSR: Essential Health and Safety Requirements (Directive 2006/42/EC)

FVL: Full variability language

HS: Harmonized standard

LVL: Limited variability language

M&CS: Monitoring and control systems

NG: Natural gas

PCM: Phase Change Material

PES: Programmable Electronic System

PL: Performance level (EN 13849-1)

PL_r: Required performance level

SIL: Safety Integrity Level

SRP/CS: Safety–Related Part of a Control System


TPE: Industrial furnaces and associated processing equipment (ISO 13555)

URS: User Requirements Specifications

VIF: VULKANO industrial furnaces

VCF: VULKANO ceramic furnace (TORRECID)

VSF: VULKANO steel furnace (VALJI)

	Document:	D6.1 User Requirements Specification for the MCS	
	Author:	Tecnalia	Version: 2
	Reference:	D6.1 VULKANO G.A. 723803	Date: 25/05/17

EXECUTIVE SUMMARY

This document aims to gather the specific requirements that a monitoring and control (M&C) system may have in industrial furnaces. As a key point, the different control techniques available for the development of new controls for furnaces are described. One of the important aspects to determine the type of control to be developed is the access to data and parameters of a system. Therefore an entire section describes the instrumentation commonly used in furnaces. The general characteristics of meters such as range, resolution, accuracy or response time have been analysed, as well as the different technologies to measure physical parameters specifying their advantages and disadvantages depending on operational conditions such as the most appropriate sensor to measure high temperatures in hard situation.

Apart from considering furnace instrumentation, a research on the control systems commonly used in industrial furnaces has been performed. Creating a model of the system to control is a starting point to understand the variables to control and their influence on the behaviour of furnaces; what is more, models provide a test bed where new developments can be checked. For this purpose, mathematical thermal models based on Kirchhoff laws to apply nodal analysis have been developed. In order to check new developments from VULKANO, a model of energy recovery system is shown. Besides, an example of energy recovery system modelled as a block of second order systems in Laplace domain is described. Besides, various industrial furnace parts have been modelled as an equivalent thermal circuit. Along with the mentioned models, three different approaches for control design are commonly used in industrial environments: the first approach shows classical theory of control system to regulate set points; the second approach is based on modern control theory that deals with Nonlinear Multi-Input-Multi-Output (MIMO) systems; and the last approach (robust control) deals with parametric uncertainty of model system. This deliverable covers the requirements and specifications for the monitoring and control systems to develop in further work packages.

Any control system will face some challenges, especially in industrial applications. In the case of VULKANO project, these challenges entail the new solutions to be developed; namely i) Phase Change Materials (PCMs) to energy recovery; ii) new advanced refractory materials; iii) burners co-firing natural gas and syngas; iv) designing new strategies of Monitoring and Control System; and v) holistic in-house predictive tool.

As VULKANO project partners are expert furnace users and developers, their knowledge is of paramount importance at the time of facing new challenges and developments. As per the end users, three sectors are involved in the project: steel sector focused on preheating; ceramic sector focused on melting process; and aluminium sector focused on heating and melting.




	Document:	D6.1 User Requirements Specification for the MCS	
	Author:	Tecnalía	Version: 2
	Reference:	D6.1 VULKANO G.A. 723803	Date: 25/05/17

TABLE OF CONTENTS

1	Introduction	1
1.1	Objective	1
1.2	Scope	1
1.3	Data gathering methodology	2
1.4	Relation to other tasks within the project	2
1.5	Structure	2
2	Furnace instrumentation	4
2.1	Meter features	5
2.2	Physical parameters	5
2.2.1	Temperature Measurement	5
2.2.2	Flow measurement	8
2.2.3	Multiphase flow meter	12
2.2.4	Thermal expansion	13
2.2.5	Deterioration of refractory	13
2.2.6	Air pressure and concentration	14
3	Furnaces modelling	15
3.1	Model Thermal systems as an electrical circuit	16
3.1.1	Heat flux (current)	16
3.1.2	Thermal resistance (current)	17
3.1.3	Thermal capacity (capacitance)	18
3.2	Energy recovery systems	18
3.3	Thermal energy storage and phase change materials	19
3.4	Model others industrial furnaces components	20
4	Control for industrial furnaces	22
4.1	Classical control theory	22
4.2	Modern control theory	23
4.3	Robust control	23
4.3.1	Uncertainty quantification	23
4.3.2	Performance specifications	24
5	Challenges for M&Cs in industrial furnaces	25
5.1	Using Phase Change Materials (PCMs) for energy recovery	25
5.2	Using New advanced refractories	26
5.3	Using burners for co-firing	26
5.4	New strategies of Monitoring and Control System	27
5.5	Others	28
6	M&Cs lesson learned	28
6.1	Steel sector	28
6.2	Aluminium sector	29

	Document:	D6.1 User Requirements Specification for the MCS	
	Author:	Tecnalía	Version: 2
	Reference:	D6.1 VULKANO G.A. 723803	Date: 25/05/17

6.3	Ceramic sector	29
7	Use cases description	31
7.1	Ceramic melting furnace (TORRECID)	31
7.1.1	Furnace technical characteristics.....	31
7.1.2	Process description.....	32
7.1.3	Furnace control.....	33
7.1.4	Project developments with impact on the M&CSs.....	34
7.2	Steel pre-heating furnace (Valji)	34
7.2.1	Furnace technical characteristics.....	35
7.2.2	Process description.....	35
7.2.3	Furnace control.....	36
7.2.4	Project developments with impact on the M&CSs.....	36
8	Users requirements specifications for the monitoring and control systems (URS-M&CSs)	37
8.1	Ceramic melting furnace (TORRECID)	38
8.1.1	Materials flow	38
8.1.2	Equipment and sensors	38
8.1.3	Energy efficiency.....	39
8.1.4	Environment	40
8.1.5	Safety	40
8.1.6	Other.....	41
8.1.7	Summary.....	41
8.2	Pre-heating furnace (Valji)	43
8.2.1	Materials flow	43
8.2.2	Equipment and sensors	43
8.2.3	Energy efficiency.....	44
8.2.4	Environment	44
8.2.5	Safety	45
8.2.6	Others	45
8.2.7	Summary.....	45
9	Impact over SPIRE roadmap.....	47
10	Conclusions	48
11	References	50

	Document:	D6.1 User Requirements Specification for the MCS	
	Author:	Tecnalia	Version: 2
	Reference:	D6.1 VULKANO G.A. 723803	Date: 25/05/17

1 INTRODUCTION

Since the project VULKANO has started, BOSIO, VALJI, TECNALIA, IEN and TORRECID has been working closely together to describe user requirements specification for M&CS in industrial furnaces with the most appropriate technologies. Also, ASAS partner has collaborated with lessons learned in aluminium industrial furnaces. The result of the work done in Task 6.1, as well as the feedback from final users is shown in this document that corresponds to deliverable 6.1.

1.1 Objective

The objectives of this deliverable are focused on two main goals. On the one hand, to describe the state of the art of monitoring and control in industrial furnaces, gathering both instrumentation currently used as well as new developments. Besides, this objective aims at describing how thermal systems are modelled and controlled. Additionally, innovative control algorithms and strategies used are studied. Finally, the investigation of the relation between new technologies (Phase Change Materials, refractories and co-firing burners) and control systems is another challenge.

On the other hand, User Requirements Specifications (URS) for the development of improved Monitoring and Control Systems (M&CS), able to be implemented in commercial PLC platforms, and considering VULKANO industrial furnaces (VIF) (ceramic and steel case studies). These URS-M&CS include end-users specifications needed to enhance the existing M&CS in order to address the new furnaces requirements.

1.2 Scope

The scope of Deliverable 6.1 includes monitoring and control issues in VULKANO industrial furnaces, particularly focused on ceramic and steel use cases but also including aluminium sector. The document aims at giving value to end-users in such industry sectors, describing the main challenges and lessons learnt to be applied when designing an M&C system. The main items are listed below:

- This deliverable approaches the two main types of industrial furnaces process (continuous vs batch).
- There are different M&C strategies, depending on the energy source. In particular, this deliverable is mainly focused on industrial furnaces powered by combustion of natural gas or similar. Industrial furnaces that use electrical energy are not addressed in such detail, whereas other furnaces that use solid materials such as tyre combustion are out of the scope of this deliverable.
- Knowledges, experiences and good practices of all industrial furnace partners (TORRECID, BOSIO-VALJI and ASAS) gathered over the years are included in this deliverable. The sectors



	Document:	D6.1 User Requirements Specification for the MCS	
	Author:	Tecnalia	Version: 2
	Reference:	D6.1 VULKANO G.A. 723803	Date: 25/05/17

considered are ceramic, steel and aluminium but the results are intended to be extrapolated to other intensive industries.

- The list of user requirement specifications is collected from the two end-users: 1) TORRECID (ceramic furnace) and 2) BOSIO/VALJI (steel furnace).
- Due to public dissemination level of this deliverable, the content of this deliverable is limited to maintain the confidentiality required by the end users (TORRECID and VALJI).

1.3 Data gathering methodology

The methodology followed to develop this deliverable is summarized by the following items:

- A state of art on industrial furnace instrumentation and control focused on specific challenges (PCM, refractories and co-firing burners) have been done by search in scientific databases such as Springer or Thomson Reuters.
- Lesson learned from ceramic, steel and aluminium sectors have been gathered by a questionnaire to industrial partners (Torrecid, Bosio-Valji and ASAS). This questionnaire contains several items about monitor, control and energy efficiency issues.
- Use cases descriptions (Torrecid, Bosio-Valji) have been collected through teleconferences, analysis of internal reports and face to face meetings. In the Torrecid use case there was a tour inside to ceramic facilities in Castellon (Spain).
- User requirements specification for monitoring and control gathered were synthesized and structured in six categories: i) Materials flow; ii) Equipment and sensors; iii) Energy efficiency; iv) Environment; v) Safety; vi) Other.
- All requirements have been summarized and prioritized into three priority levels for implementation (High, Medium and Low, corresponding to colours red, orange and yellow). Although the high priority requirements have been selected to develop the future functional design specification for MC&S in industrial furnaces (Task T6.2 and corresponding deliverable D6.2), the medium and low priority requirements will be taken into account.


1.4 Relation to other tasks within the project

Deliverable D6.1 will be used as a fundamental input for Task 6.2 and Deliverable 6.2, where final user requirement specifications for monitoring and control systems of VULKANO industrial furnaces will be selected and specified for their implementation in case studies.

1.5 Structure

Deliverable D6.1 is organized as follows:

Section 2 is dedicated to furnace instrumentation. This section addresses the general characteristics of meters such as range, resolution, accuracy or response time. Also it analyses different technologies to measure physical parameters specifying the advantages and

	Document:	D6.1 User Requirements Specification for the MCS		
	Author:	Tecnalía	Version:	2
	Reference:	D6.1 VULKANO G.A. 723803	Date:	25/05/17

disadvantages depending on operational conditions such as the most appropriate sensor to measure high temperatures in hard situation.

Section 3 shows general models of industrial furnaces from the point of view of the control system. This section reflects mathematical thermal models based on Kirchhoff laws to apply nodal analysis. A model of energy recovery system is showed. Besides, an example of energy recovery system modelled as a block of second order systems in Laplace domain is described. Furthermore, various industrial furnace parts are modelled as an equivalent thermal circuit.

Section 4 develops various approaches of designing controllers for industrial furnaces. The first approach shows uses classical theory of control system to regulate set points. The second approach is based on modern control theory that deals with Nonlinear Multi-Input-Multi-Output (MIMO) systems. The other approach (robust control) deals with parametric uncertainty of model system.

Section 5 describes the new challenges for monitoring and control systems in industrial furnaces. This section is focused on four important innovative solutions, to be developed under the framework of the project: i) Phase Change Materials (PCMs) to energy recovery; ii) new advanced refractory materials; iii) burners co-firing natural gas and syngas; iv) designing new strategies of Monitoring and Control System and holistic approach.

Section 6 includes the specific lessons learned on M&CSs from all industrial VULKANO partners (Torrecid, Bosio-Valji and ASAS): Steel sector focused on preheating, ceramic sector focused on melting process, and aluminium sector focused on heating and melting.

Section 7 develops the technical description of two main use cases: Torrecid and Bosio-Valji, including: i) furnace technical characteristics; ii) process description; iii) furnace control; iv) project development with impact on the M&CSs.

Section 8 shows the requirement specification for monitoring and control systems for Torrecid use case and Bosio-Valji use case. The user requirement specifications are divided into six categories: i) Materials flow; ii) equipment and sensors; iii) energy efficiency; iv) environment, iv) safety and vi) other. Finally, a summary of the most important specifications is given by means of a table.

Section 9 describes the conclusions obtained and the future steps to be taken.

2 FURNACE INSTRUMENTATION

An industrial furnace can be represented by Figure 1, showing a schematic representation of a machine [REF ISO 12100:2010].

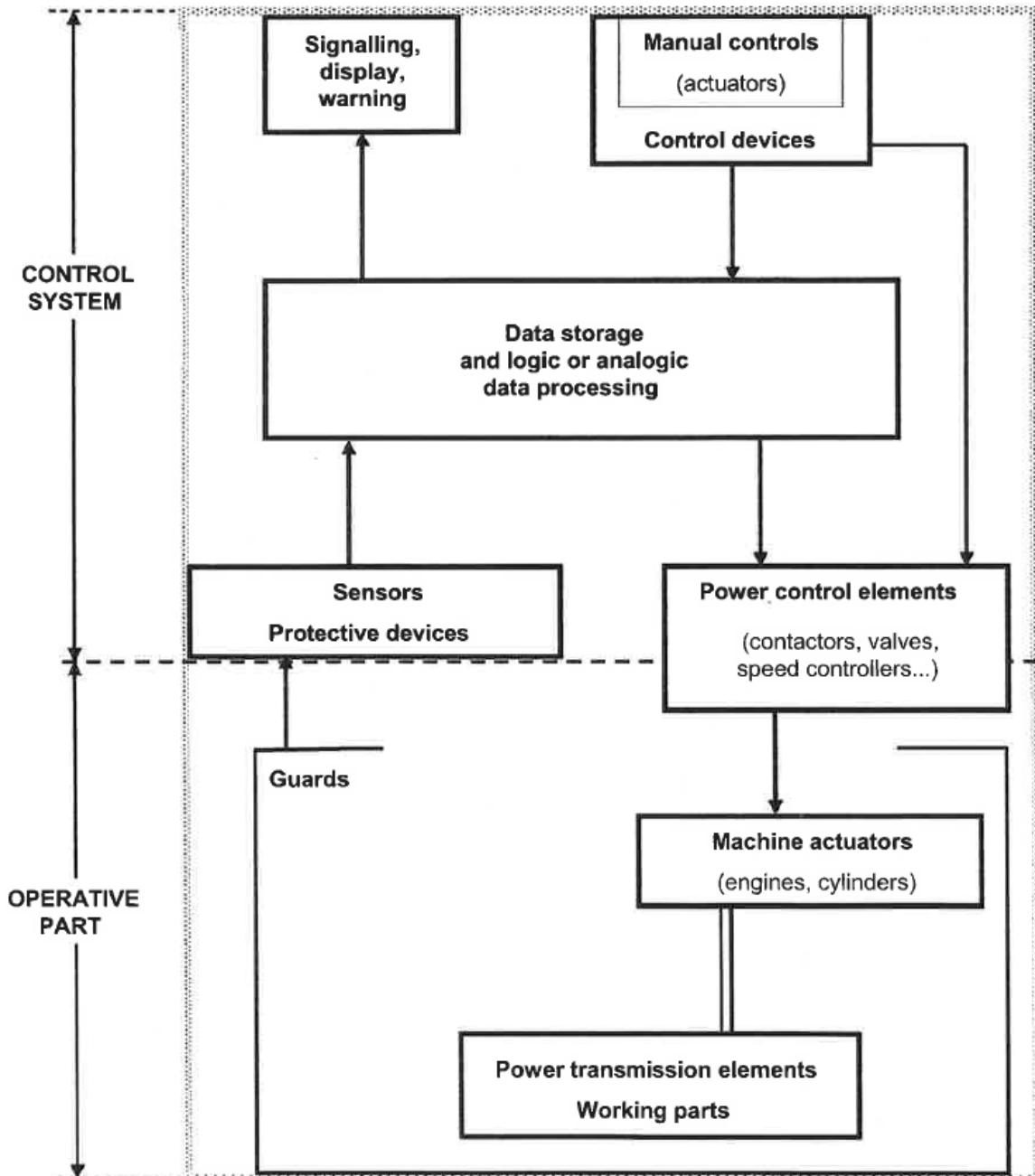



Figure 1. Schematic representation of a machine.

Section 2.1 describes the main quantity features of a meter such as range, resolution, accuracy and response Time. Section 2.2 deals with different physical parameters to be measured, such as

	Document:	D6.1 User Requirements Specification for the MCS	
	Author:	Tecnalía	Version: 2
	Reference:	D6.1 VULKANO G.A. 723803	Date: 25/05/17

temperature, and also the diverse technologies used to face the hard conditions that sensors must endure e.g. ultrasonic waves.

2.1 Meter features

Suitable monitor is a key element of the furnace control system. If the furnace performance parameters cannot be measured reliably, then the furnace cannot be effectively controlled.

Data is gathered by different kind of sensor that detects events or changes in its environment and sends it in electronic format. These electrical signals are transformed into data. The items below describe an overview of the characteristics to be taken into account when considering the reliability of a meter.

- **Range:** maximum and minimum values that can be measured.
- **Resolution:** smallest detectable change that can be detected.
- **Accuracy:** maximum difference that will exist between the measure value (which must be measured by a primary or good secondary standard) and the indicated value at the output of the sensor.
- **Response Time:** the time required for a sensor output to change from its previous state to a final settled value within a tolerance band of the correct new value.

Other aspects that must be taken into account are maintenance costs and the life cycle of the meters.

2.2 Physical parameters

Industrial furnaces require several sensors to be monitored in a suitable manner. Owing to the different varieties of sensors, they are clustered according to the physical feature that measures.

This section is organized as follows: Section 2.2.1 shows different technologies to measure temperature. Section 2.2.2 describes techniques to measure the volume rate of material flow that is transported through a given cross-sectional area. Section 2.2.4 deals with various ways to measure the furnace structure alteration in shape, area, and volume as a consequence of temperature variation (thermal expansion). Section 2.2.5 lists meters to assess the refractory life cycle. Finally, Section 2.2.6 includes meters to gather air pressure inside the furnace chamber.

2.2.1 Temperature Measurement

Although temperature measured in Kelvin units is used in scientific ambient due to be an International System of Units, Celsius unit is further used due to its suitable scale based on freezing and boiling point of water.

Although distributions of temperature, heat flux, and heat transfer coefficient are determined by means of computer modelling heating process (Honner et al. 2003), furnace temperature can be

measured by a number of contact and non-contact devices. The most common devices are: Thermocouples; Resistance thermometers; Ultrasonic acoustic devices and Radiation pyrometers.

2.2.1.1 Radiation

The infrared or other optical techniques such as thermography cameras are noncontact or non-destructive temperature measurement. These devices give surface temperatures based on the emitted radiance of heated materials by means of use Planck's radiation law and Wien approximation. Infrared radiations meters are not appropriate for monitoring internal temperatures because they only give surface temperatures (Wei et al. 2017).

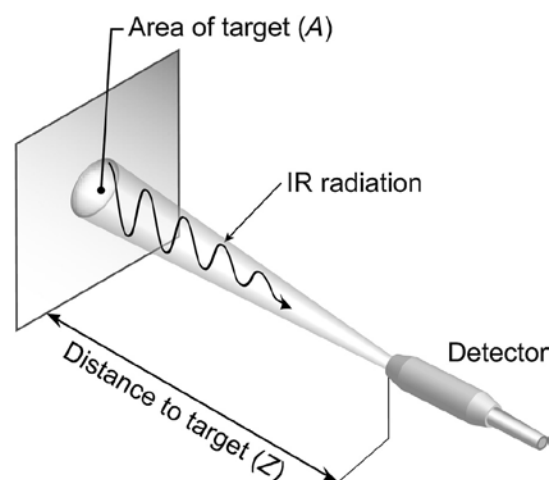



Figure 2. Remote temperature measurement using infrared radiation.

A thermography camera is a device that forms an image using infrared radiation and has the advantage of monitoring a wide field of view distantly. Thermography camera is used to remotely measure temperatures (Wang et al. 2015).

Although IR emissivity of target material increases with temperature, calibration of IR detector depends on nature of materials and surface conditions. Measure error arises when furnace atmosphere is contaminated by particles, mainly dust and gases (CO_2 and H_2O), that absorbs and reradiates infrared radiation. Another source of error appears when window pyrometers are contaminated by dust particles suspended in the air. A method to reduce errors across a wide temperature range is proposed in (Lowe et al. 2015).

There are several examples of use infrared to measure temperature in industrial furnaces. In (Švantner et al. 2013) is presented a non-contact temperature measurement procedure on a continuous steel furnace that has several advantages. However, there are some problems regarding the measurement set-up calibration and charge emissivity, which is a very important in IR temperature measurement applications.

The main drawback of this technology resides on the impossibility of measure internal temperatures of radiance bodies. This disadvantage is crucial in heat treatment owing to the difficulty to ensure that the required temperatures in all points are achieved.

	Document:	D6.1 User Requirements Specification for the MCS	
	Author:	Tecnalia	Version: 2
	Reference:	D6.1 VULKANO G.A. 723803	Date: 25/05/17

2.2.1.2 Thermocouples

A thermocouple is an electrical device consisting of two dissimilar conductors forming electrical junctions at differing temperatures. A thermocouple produces a temperature-dependent voltage as a result of the thermoelectric effect, and this voltage can be interpreted to measure temperature. Thermocouples are widely used as a temperature sensor.

Although a conventional thermocouple technique is widely used and covers a wide temperature range, it is not always acceptable because of its limitation of installation and destructive detection mode (Wei et al. 2017).

The main drawbacks of thermocouples are: i) Observational deviations of conversion characteristic produce error between 2.5 and 8°C when measuring temperatures between 333°C and 1100°C. ii) Considerable error due to drift of conversion characteristic during operation. iii) Degradation of thermocouples features as a result of prolonged operations at high temperatures (Zhengbing et al. 2016).

To reduce the observational error between a measured value and its true value there are several techniques based on using functional transformation with a mathematical function or a neuronal network (Zhengbing et al. 2016). The error of the thermocouple can be measured with different methods: using a new reference thermocouple that allows comparison or using a fixed temperature for physical space.

In (Fu et al. 2017) is proposed a temperature difference measurement approach based on compound thermocouple with empirical equations to calibrate, which reduces the averaged error.

In (Martínez et al. 2017) is presented a technique to retrieve the wall temperature in scraped surface heat exchangers based on embedded thermocouples welded directly into the wall plate where thermocouple location is important.

2.2.1.3 Resistance thermometers

Resistance thermometers are widely used to monitor temperature. They measure temperature by means of electrical resistivity of materials compounded that fluctuates from few Ohms to few mega-Ohms (Olivieri et al. 2015). They are also named Resistance Temperature Detectors (RTD) for process control and to assess the operational status and safety due to the good calibration and fast dynamic response time (Montalvo et al. 2014).

Any conductor could theoretically be used as a resistance temperature detector. However, the variation in electrical resistance with temperature is non-linear and sensitive to strain. The resistivity of platinum ($\approx 10 \mu\Omega/\text{cm}$) is six times of copper's, platinum is relatively unreactive, having a high melting point (1769°C) and, because it has a well-established temperature coefficient of resistance, it is a common choice for the precise measurement of temperatures between -260°C and 1000°C (Childs 2001).

In (Olivieri et al. 2015) is presented a method to realize a full range resistive thermometer, capable of reading temperatures with high precision over the whole 300 K-10mK range.

	Document:	D6.1 User Requirements Specification for the MCS		
	Author:	Tecnalia	Version:	2
	Reference:	D6.1 VULKANO G.A. 723803	Date:	25/05/17

2.2.1.4 Ultrasonic acoustic devices

The principle of temperature measurement by ultrasound is based on temperature dependence of the speed at which sound travels through a material (acoustic velocity) (Arthur et al. 2005). The speed of sound is measured by determining the time taken for the sound wave to cross.

“Although ultrasonic temperature measurement typically uses piezoelectric devices in physical connection with component to measure with a limited operating temperature range due to the choice of materials used and the way they are glued together, a prototype flexural ultrasound transducer capable of operating at temperatures up to 500°C is presented” (Burrows et al. 2016).

Ultrasound is an attractive modality for measuring internal temperature distributions in heated structures, because of its capability to probe the interior of materials and its high sensitivity to temperature (Ihara & Takahashi 2007).

In (Wei et al. 2017), it is presented a new ultrasonic method with good robustness and accuracy for reconstructing internal temperature distribution in a heat material, where heat conduction problems of transient state boundaries are solved by quasi-steady approximation.

2.2.2 Flow measurement

Industrial furnaces require various ducts or pipelines to conduct gases, liquid and mixed to convey from one point to another. Monitoring those fluids displacement requires the installation of sensors to quantification of bulk fluid movement.

To select the appropriate flow meters, it is necessary to consider different aspects: i) maintenance cost required as a result of multiplication frequency and harshness, ii) type of fluid moved through the ducts, according to its features such as corrosive or abrasive fluid, leading to robust or non-invasive meters because pipe needs to be replaced frequently, iii) portability or plug and play installation feature to change meters location from time to time (Zuzunaga & Maron 2013). Flow measurement sensors can be clustered by grade of contact between the measure device and fluid (invasive, non-invasive and semi-invasive) (Zuzunaga & Maron 2013).

2.2.2.1 Ultrasonic flow sensors

2.2.2.1.1 Non-invasive flow meters

Non-invasive flow meters can measure the flow movement without any contact between them. One example are the Ultrasonic flow meters, which measure flow speed by using ultrasonic waves travelling from transmitter in the direction of flow to receivers (Zuzunaga & Maron 2013). On the one hand, the main advantages reside on less maintenance requirements, easy and portable installation that suit on different duct diameters and nonexistence of moving part. On the other hand, the main drawbacks are lack of accuracy for some applications control requirements, flow liquids must be clear to proper measure and, scale build up decreases the accuracy of the meter. (Zuzunaga & Maron 2013)

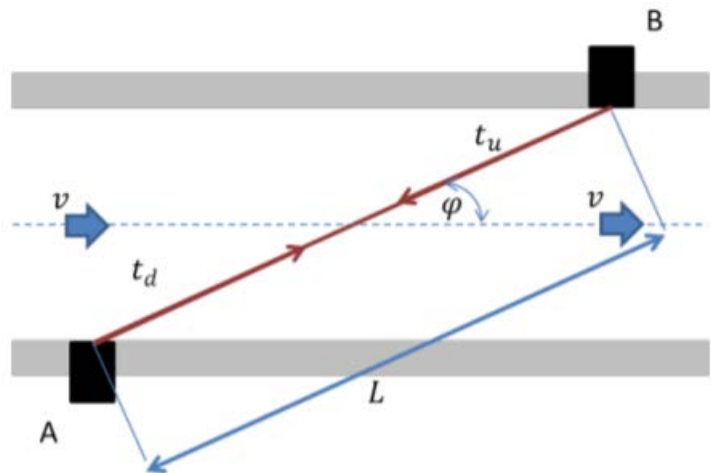


Figure 3: Ultrasonic flow meter (Zuzunaga & Maron 2013).

Other example of measure flow speed is doppler ultrasonic flow meters, using the Doppler Effect. The fluid speed is calculated by means of ultrasonic frequency measured between source and receiver. On the one hand, the main advantages reside on plug and play installation, and a single instrument which can be installed on many different pipe diameters, making this a very portable flow meter. On the other hand, the main disadvantages are the non-sufficient accuracy level for certain applications control due to the impossibility to work with high solids concentration and with upper flow rate. Figure 3 shows how an Ultrasonic wave Doppler flow meter works. (Zuzunaga & Maron 2013)

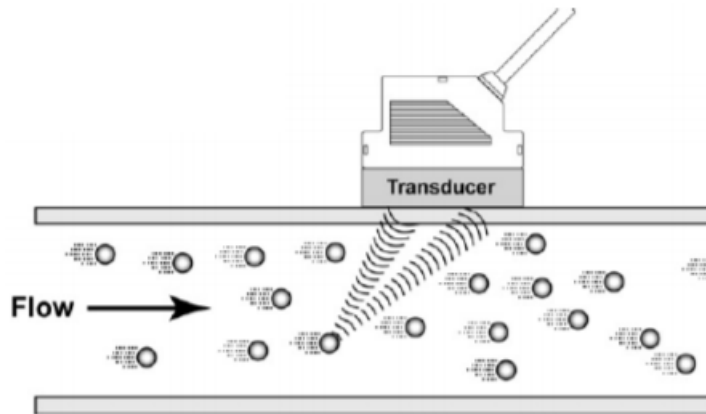


Figure 4: Ultrasonic wave Doppler frequency shift

Other type of flow meter is hybrid ultrasonic flow meters that combine ultrasonic fluid wave and Doppler ultrasonic. Hybrid architecture improves the accuracy compared with simple ultrasonic technologies but it is not enough for some control applications. (Zuzunaga & Maron 2013)

Additional type of flow meters is array-based sonar flow meters that use an array of piezoelectric sensors around the duct. Flow rate is calculated by using array of measures gathered from sensors with information about speed of vortex structures. The main advantages are good accuracy, no coupling is needed, flow liquid with solid particles can be measured and it is capable to measure

upper flow rate. The main disadvantages are delays in interpretation and outcome measure result, owing to the time needed to process array of data gathered (Zuzunaga & Maron 2013).

2.2.2.1.2 Semi-invasive flow meters

Semi-invasive flow meters are characterized by small contact with the flow through; normally there is a minor hole where the sensor is inserted. One semi-invasive method is wetted transit time ultrasonic flow meter. The main advantages are: moderate easy to mount, acceptable accuracy for majority of process and the reasonable response time. The main disadvantages are: frequency maintenance is required in aggressive fluids and scale meters affect the accuracy. (Zuzunaga & Maron 2013)

Other technique is the insertion magnetic flow meters that use Faraday's law of induction. The generated voltage is proportional to the velocity of the conductor. The main disadvantages are: i) a drilled into pipe is required, ii) scale build-up affects the accuracy, iii) it is not adequate to be installed in pipes with high pressure, iv) it requires frequency maintenance with abrasion fluids. (Zuzunaga & Maron 2013)

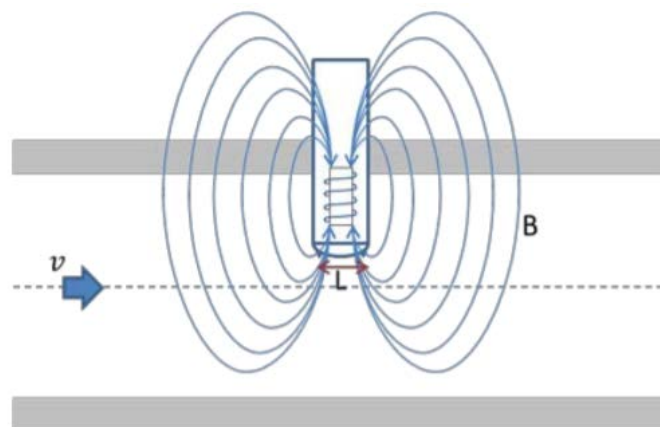


Figure 5: example of semi-invasive flow meters.

2.2.2.2 Mechanical flow sensors

This kind of meters use a physical displacement of subcomponents to measure the liquid flow through the meter. There are different mechanical techniques to measure, some of main common ones are: i) piston meter or rotary piston uses a chamber of known volume. They are mainly installed to measure water consumption. ii) Variable area meter measures fluid flow by allowing the cross sectional area of the device to vary in response to the flow, causing some measurable effect that indicates the rate. iii) Turbine flow meter transforms mechanical actions (angular speed of turbine) into flow units. Water management systems use mechanical flow meters to monitoring and control. The range of isolating, regulating and control valves installed in raw and potable water assets including gate, butterfly, globe, screwdown, ball, plug, diaphragm, pinch, needle sleeve and hollow-jet and non-return valves is described in (Brandt et al. 2017).

2.2.2.3 Pressure flow sensors

Orifice Plate: An orifice plate is a thin plate with a hole in it, which is usually placed in a pipe. When a fluid (whether liquid or gaseous) passes through the orifice, its pressure builds up slightly upstream of the orifice but, as the fluid is forced to converge to pass through the hole, the velocity increases and the fluid pressure decreases. The performance of orifice plates in real-time monitoring of oil, gas and water standard flow rates was investigated (Campos et al. 2014).

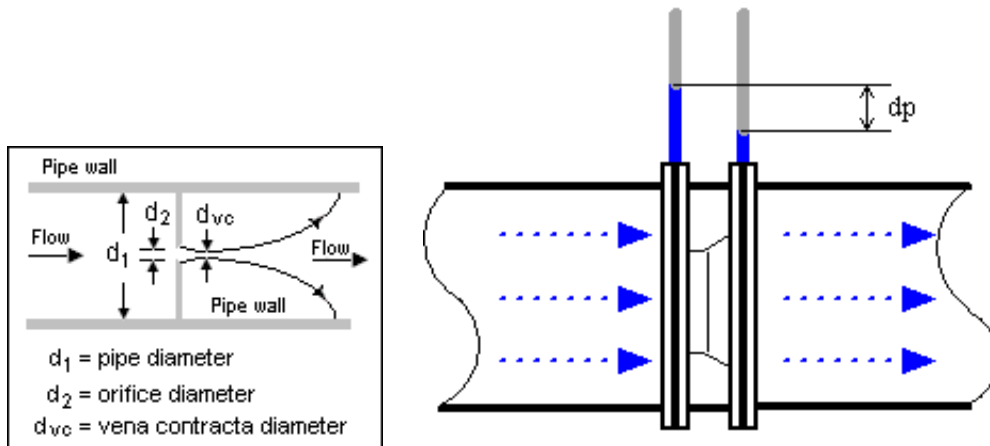


Figure 6: Orifice Plate (www.engineeringtoolbox.com)

Flow nozzle: Figure 7 shows the operation of flow nozzle. This meter is mainly installed in applications to measure air or gas.

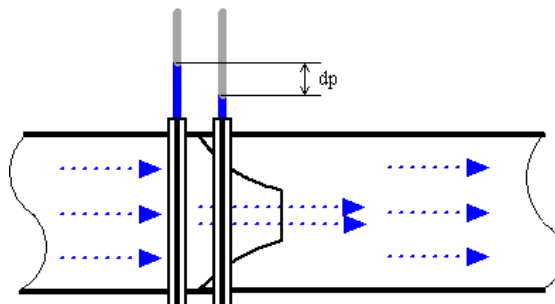


Figure 7. Flow nozzle (www.engineeringtoolbox.com)

Venturi tube: Figure 8 shows the operation of Venturi tube. In the Venturi Tube the fluid flowrate is measured by reducing the cross sectional flow area in the flow path, generating a pressure difference.

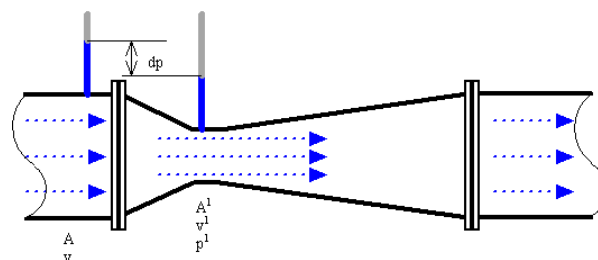



Figure 8. Venturi tube (www.engineeringtoolbox.com)

	Document:	D6.1 User Requirements Specification for the MCS	
	Author:	Tecnalia	Version: 2
	Reference:	D6.1 VULKANO G.A. 723803	Date: 25/05/17

Use of an elbow as a flow meter: By using an existing elbow in the piping system, the pressure of fluid is determined by a slight pressure differential when fluid passes through an elbow. The figure below shows an example of this type of meter.

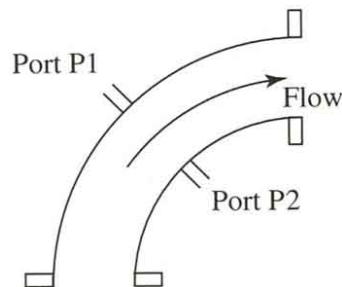



Figure 9: an elbow as a flow meter

However, flow rates of “dirty” gases, such as coke oven gas, are more difficult to measure due to the adverse effect that impurities, such as suspended particles and tars, have on many flow measuring systems. For example, pressure differential devices tend to suffer from rapid blocking of the tapping points whereas devices that are dependent on specific shapes, such as orifice plates and vortex shedding meters, suffer drift owing to sensor wear caused by particle attrition or deposit build up owing to condensation of tar, etc.

2.2.3 Multiphase flow meter

A multiphase flow meter is a device used to measure the individual phase flow rates of constituent phases in a given flow. There are different methods to provide multiphase flow metering and flow characterization. A new type of multiphase flow meter is shown in (Pirouzpanah et al. 2014), where the performance of a modified version of a close coupled slotted orifice plate and swirl flow meter for multiphase flow was evaluated.

The factors influencing the character of the melt flow were defined and examined in a model glass melting space. The batch blanket was simulated by an inflowing glass melt with sand particles and bubbles and the heating elements by the defined volumes of the melt where heat was evolved. The character of the melt flow was set up by a proper arrangement of the heating elements in the space. The sand dissolution and the bubble removal were modelled in the space; the space utilization, melting performance, and heat losses were calculated. The required character of the melt flow was brought about by the energy evolution in the region of the longitudinal space axis and by the supply of a substantial part of energy to the region beneath the inflowing melt. The results of the modelling have confirmed that the suitable flow character in the space was a helical-like flow, which was attained by the combination of an almost uniform forward flow with imposed transversal melt circulations. High values of the space utilization, several times higher melting performance and proportionally lower specific heat losses were acquired when compared with the values attained under conditions simulating the melt flow in industrial melting furnaces (Jebavá et al. 2015).

	Document:	D6.1 User Requirements Specification for the MCS	
	Author:	Tecnalia	Version: 2
	Reference:	D6.1 VULKANO G.A. 723803	Date: 25/05/17

2.2.4 Thermal expansion

There are various monitoring techniques for structural integrity monitoring of industrial furnaces. Some indirect techniques are based on monitoring the temperature measurements using thermocouples or fiber-optic sensors. The Tapblock Diagnostic System (TDS) is an advanced on-line monitoring system that uses temperature data along with embedded thermal model results to evaluate the condition of a tapblock over its campaign life (Braun et al. 2016).

One common technique for furnace monitoring is based on direct measurements of furnace expansion in relation to the supporting structures or bindings (springs and stiffeners). Scanning of the topology of the entire vessel provide valuable results combined with other measurements (Braun et al. 2016).

The tapblock is the fastest wearing component of the furnace, and as a result requires a maintenance programme. The Taphole Acoustic Monitoring makes use of acoustic emission events from the tapblock to evaluate the condition of the refractory lining and copper coolers within the block (Braun et al. 2016).

2.2.5 Deterioration of refractory


Industrial furnaces are designed and operated to resist severe thermal, mechanical, and chemical conditions. Furnaces are lined by refractory bricks to protect the structure against the harsh operational environment.

Refractory is a composition of materials that are resistant to the heat, and to the chemical and mechanical attacks that occur during the smelting process. The exact composition of the refractory material and its arrangement in a furnace is designed based on the particular smelting process and furnace type.

The severe conditions inside the furnace cause deterioration of the refractory lining almost immediately after furnace start-up. The deterioration is mainly caused by thermal stresses and chemical attacks, resulting in loss of heat-transfer and load-bearing capabilities. Overtime, the lining wear progresses, in large part due to cycles of maintenance shutdowns and start-ups. Eventually, this wear results in the reduction of the furnace campaign life. Early detection of refractory wear and continuous or periodic monitoring of lining condition are essential tasks that help continuous, safe operation of a furnace. Failure of the lining is dangerous and can affect the structural integrity of the furnace. The degree and mechanism of deterioration depends on many different factors (Sadri et al. 2016).

The methods to Measure and Monitor Refractory Lining are show below.

By temperature monitor in several parts: The most common technique is the use of temperatures and thermal fluxes to determine the remaining lining thickness. To get the refractory temperatures, operators insert thermocouples into the lining at various locations and depths into the lining. Temperatures are collected continuously from the thermocouples. Based on the thermal flux values from the thermocouples and the thermal properties of the refractory materials, the remaining lining thickness is calculated. While this is an essential and useful

	Document:	D6.1 User Requirements Specification for the MCS	
	Author:	Tecnalia	Version: 2
	Reference:	D6.1 VULKANO G.A. 723803	Date: 25/05/17

refractory condition monitoring system, it has some limitations. For example the mathematical models used to calculate the remaining lining thickness are designed based on various assumptions that may be incorrect or inaccurate. Additionally, the number of thermocouples, their distribution and their quality affects the calculations (Sadri et al. 2016).

By thermal cameras: Thermal cameras are extensively used for furnace assessments because the cameras are easy to use, reasonably priced, and globally available. Around the furnaces, the main use of a thermal camera is to detect “hot spots” on the vessels. Hot spots can indicate increased refractory wear in particular areas, metal penetration, or other anomalies. For accurate wear detection, infrared cameras can be utilized to determine the refractory loss in single-lined vessels such as a kiln, converter or reactor. However, the complex, multilayered refractory present in furnaces means that shell temperature is not always a good indicator of the lining condition of furnaces. Thus thermal cameras are not capable of effectively monitoring furnace linings (Sadri et al. 2016).

By electromagnetic reflection systems for the detection of flaws and refractory thickness measurements. They are not a practical approach for refractory measurements in smelting furnaces due to pulses cannot penetrate the metallic shell (Sadri et al. 2016).

By acoustic Ultrasonic-Echo (AU-E): it was developed in late 1990s based on impact echo concrete testing principles. AU-E is a stress wave propagation technique that uses time and frequency data analysis to determine refractory thickness, and to detect anomalies such as cracks, gaps or metal penetration within the refractory lining. During the measurement, a mechanical impact on the surface of the structure (via a hammer or a mechanical impactor) generates a stress pulse, which propagates into the refractory layers. The wave is partially reflected by the change in material properties, but it also propagates through the solid refractory layers all the way up to brick/brick or brick/gas or brick/molten metal interfaces (Sadri et al. 2016).

By acoustic emission: this technique is very powerful and underdeveloped. Acoustic Emission testing is a proven method for examining the behaviour of materials deforming under stress. An acoustic emission can be defined as a transient stress wave generated by the rapid release of energy within a material. There are two main furnace monitoring systems. The first system, Taphole Acoustic Monitoring system (TAM), is used for monitoring furnace tapholes. Tapholes are the area where the hot metal or slag is allowed to flow out of the furnace. The second system monitors the furnace structure. It can help prevent molten metal leaks, as well as help with a variety of process issues (Sadri et al. 2016).

2.2.6 Air pressure and concentration

Combustion is a high-temperature exothermic redox chemical reaction between a reductant and an oxidant. The combustion conditions are strongly dependent on the pressure and temperature as well as oxygen concentration. High concentration of carbon monoxide (CO) is produced when there is not enough oxygen to react completely (Glassman & Yetter 2008).

	Document:	D6.1 User Requirements Specification for the MCS	
	Author:	Tecnalia	Version: 2
	Reference:	D6.1 VULKANO G.A. 723803	Date: 25/05/17

Normally, the CO concentration is measured in parts per million. There are several types of CO meters, for example, shows a portable carbon monoxide detector that can detect carbon monoxide concentration, observing concentration value all the time. It has quite clear large LCD screen and voice and light alarm indication.



Figure 10. Handheld Carbon Monoxide Meter CO Gas Tester 0-1000ppm Monitor Detector

3 FURNACES MODELLING

Although Computational Fluid Dynamics (CFD) techniques have been the most widely used methods to simulate heat systems (Yin & Yan 2016), they need huge computational resources to provide useful information. CFDs are useful to extract information in steady state or continue state but they are not suitable to be executed in transition states (Hu et al. 2016).

Design controllers for control systems require performing several frequency and temporal transient simulations in order to define the most appropriate controller parameters. This reason makes not adequate to use CFDs techniques directly with software for simulation and control. New modelling approach combines the advantages of CFD in 3 dimensions and other method more simple to overcome the difficulties to use three-dimensional flow field (Hu et al. 2016). Nonlinear ordinary differential equations and differential equations in general are one of the most popular frameworks for describing the temporal evolution of a wide variety of systems such as transfer of heat from one substance to another.

This section 3 is organized as following: Section 3.1 shows the way to model thermal systems as an equivalent electrical circuit. Section 3.2 describes a model of energy recovery system. Section 3.3 deals with a model of a thermal energy storage and phase change materials. Finally, section

Document:	D6.1 User Requirements Specification for the MCS		
Author:	Tecnia	Version:	2
Reference:	D6.1 VULKANO G.A. 723803	Date:	25/05/17

3.4 develops various industrial furnace components (combustion chamber, air input, chimney, loads and gas burner) represented as an equivalent thermal circuit.

3.1 Model Thermal systems as an electrical circuit

The law of heat conduction, also known as Fourier's law, states that the time rate of heat transfer through a material is proportional to the negative gradient in the temperature and to the area, at right angles to that gradient, through which the heat flows.

Thermal system can be represented by an equivalent thermal circuit. The heat flow can be modelled by analogy to an electrical circuit where heat flow is represented by current, temperatures are represented by voltages, heat sources are represented by constant current sources, and absolute thermal resistances are represented by resistors and thermal capacitances by capacitors.

3.1.1 Heat flux (current)

Heat flux is the rate of heat energy transfer through a given surface per unit of time. There are three different ways where heat can flow from one substance to another: conduction, convection, and radiation.

Thermal Conduction is the process of heat transfer based on direct contact between bodies, without exchange of matter. The heat flows from higher temperature body to lower temperature body. The equation of thermal conduction, can be expressed as Ohm's law ($I = V \cdot R^{-1}$), is showed below.

$$\underbrace{\begin{pmatrix} \mathbf{q} \end{pmatrix}}_{\substack{I \\ \parallel \\ \text{Current}}} = \underbrace{\begin{pmatrix} -\nabla T \end{pmatrix}}_{\substack{V \\ \parallel \\ \text{Voltage}}} \cdot \underbrace{\begin{pmatrix} \mathbf{k} \end{pmatrix}}_{\substack{R^{-1} \\ \parallel \\ \text{inverse resistance}}} \quad (1)$$

Where q is the heat flux density in $W \cdot m^{-2}$, ∇T is the temperature gradient in $K \cdot m^{-1}$ and k is the thermal conductivity of the material in $W \cdot m^{-1} \cdot K^{-1}$. shows an example of one-dimensional heat conduction.

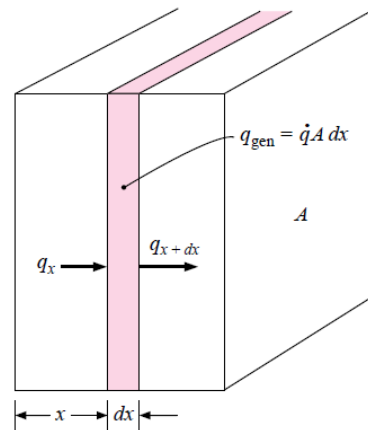


Figure 11. Elemental volume for one-dimensional heat conduction

Thermal Convection is the transfer of heat from one place to another by the movement of fluids. The equation of thermal convection, can be expressed as Ohm's law ($I = V \cdot R^{-1}$), is showed below.

$$\underbrace{\left(\overset{I}{\parallel} \right)}_{\text{Current}} = \underbrace{\left(\overset{V}{\parallel} \right)}_{\text{Voltage}} \cdot \underbrace{\left(\frac{1}{h \cdot A} \right)}_{\text{inverse resistance}} \quad (2)$$

Where A is the surface of the object in m^{-2} , h is the convection heat transfer in $W \cdot m^{-2} \cdot K$ and ΔT is the temperature difference between the object and the fluid in K .

Thermal radiation is the heat transfer propagated directly proportional to its surface area by electromagnetic radiation as a result of a temperature difference. The equation of Stefan-Boltzmann law of thermal radiation is showed below.


$$\underbrace{\left(\overset{I}{\parallel} \right)}_{\text{Current}} = \epsilon_1 \cdot \sigma \cdot A \cdot (T_1^4 - T_2^4) \quad (3)$$

Where σ is the Stefan-Boltzmann constant ($5.669 \cdot 10^{-8} W \cdot m^{-2} \cdot K^4$) and ϵ_1 is an emissivity parameter.

3.1.2 Thermal resistance (current)

Thermal resistance is a measurement of a temperature difference characterized of ability of a material to resist the flow of heat. The thermal resistance of a specific component is measured in $K \cdot W^{-1}$ units. The thermal resistance for heat transfer between two substances may be defined as follows:

$$R = \frac{\Delta T}{q} = \frac{\overset{\text{Conductivity}}{\widehat{k \cdot A}}}{\Delta x} = \frac{\overset{\text{Convection}}{\widehat{h \cdot A_s}}}{\Delta x} \quad (4)$$

	Document:	D6.1 User Requirements Specification for the MCS	
	Author:	Tecnalia	Version: 2
	Reference:	D6.1 VULKANO G.A. 723803	Date: 25/05/17

The behaviour of a set of thermal resistances is similar to a set of electrical resistances when total equivalent resistance is calculated. On the one hand, serial resistances can be directly summed to calculate an equivalent resistance as shows below:

$$R_{eq} = \sum_{i=1}^{i=n} R_i \quad (5)$$

On the other hand, parallel resistances can be inversely summed to calculate an equivalent resistance as shows below.

$$R_{eq} = \sum_{i=1}^{i=n} \frac{1}{R_i} \quad (6)$$

3.1.3 Thermal capacity (capacitance)

Thermal capacity is defined as the ratio of heat transferred to or from the system and the resulting change in temperature in the system. The equation below shows the calculation of specific heat capacity in $[J \cdot kg^{-1} \cdot K^{-1}]$ units.

$$C = \frac{\text{change in heat stored}}{\text{change in temperature}} \quad (7)$$

The Equation below shows the behaviour (temperature and heat flux) over time of a thermal capacitance (transient).

$$q(t) = C \cdot \frac{dT}{dt} \quad (8)$$

3.2 Energy recovery systems

In process involving production or absorption of energy in the form of heat, heat exchangers are commonly used to transfer heat from the hot fluid through a solid wall to a cooler fluid without adding energy to the process. There are different types of heat exchanger used in the industry. They mainly depend on the heat transfer area, temperature difference in the fluid flow rate and their fluid flow pattern.

Figure 12 shows an elemental heat exchanger Blocks diagram where $T_{1,in}$ is the input temperature of cold fluid in Kelvin units, $T_{1,out}$ is the output temperature of cold fluid in Kelvin units, Q_1 is the volumetric flow rate of cold fluid in $[m^3 \cdot s^{-1}]$, Cp_1 is the heat capacity of cold fluid in joule per kelvin $[J \cdot K^{-1}]$ units, $T_{2,in}$ is the input temperature of steam fluid in Kelvin units, $T_{2,out}$ is the output temperature of steam fluid in Kelvin units, Q_2 is the volumetric flow rate of steam fluid in $m^3 \cdot s^{-1}$, and Cp_2 is the heat capacity of steam fluid in joule per kelvin $[J \cdot K^{-1}]$ units.

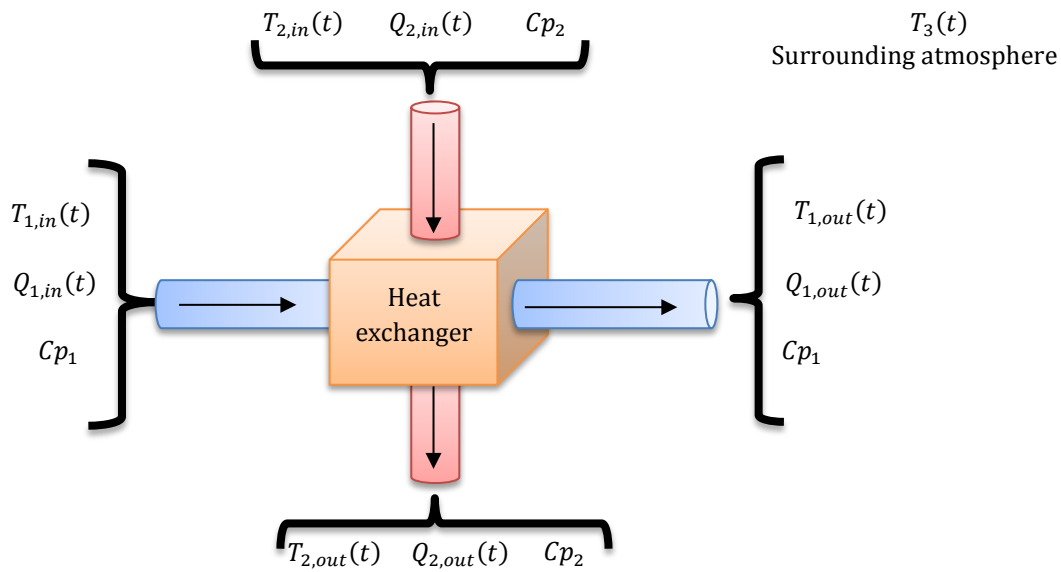


Figure 12. elemental heat exchanger Blocks diagram

The transfer function of a plate type heat exchanger after linearizing and Laplace transform (Saranya et al. 2017) is.

$$G(s) = \frac{T_{co}(s)}{m_h(s)} = \frac{H \cdot (T_\alpha \cdot s + 1)}{T_p^2 \cdot s^2 + 2 \cdot \psi \cdot T_p \cdot s + 1} \quad (9)$$

Where $G(s)$ is the transfer function, $T_{co}(s)$ is the outlet cold water temperature, $m_h(s)$ is the hot water flow rate, H is the Constant, T_α is the lead time constant, T_p is the Lag time constant and ψ is damping coefficient. Modelling and Control of Plate Type heat exchangers using PI (Proportional Integrative) and PID (Proportional, Integrative and Derivative) controllers

$$m_c \cdot C_p \cdot T_{ci} + UA \cdot \left[\frac{T_{hi} + T_{ho}}{2} - \frac{T_{ci} + T_{co}}{2} \right] - m_c \cdot C_p \cdot T_{ci} \quad (10)$$

Flow-induced tube vibration could cause serious damage on large-scale circulating-water heat exchanger in factories. Therefore, efficient inspection technology is very important for heat exchanger's blockage and leakage. The existing detection technologies, like temperature test and pressure test, are very easily affected by extraneous factors, while the non-destructive testing technology based on vibration sensors is free from above limits. Vibration sensors to detect blockage and leakage of the circulating-water heat exchanger is used (Pang et al. 2013).

3.3 Thermal energy storage and phase change materials

Thermal energy storage systems for both heat and cold are necessary for good performance of many industrial processes. The energy storage density in sensible heat storage is determined by the specific heat capacity of the storage media and the temperature changes. The sensible heat stored in any material can be calculated as follows:

$$Q_{sensible} = \int_{T_1}^{T_2} C_P \cdot dT \quad (11)$$

where $Q_{sensible}$ is the sensible heat stored, C_P the specific heat of the material, and dT the temperature change. The energy storage density could be increased using PCM, having a phase change (latent heat) within the temperature range of the storage. Considering the temperature interval $\Delta T = T_2 - T_1$, the stored heat in a PCM can be calculated as follows:

$$Q_{latent} = \int_{T_1}^{T_{PC}} C_S \cdot dT + \Delta H_{ls} + \int_{T_{PC}}^{T_2} C_L \cdot dT \quad (12)$$

where Q_{latent} is the sensible and latent heat stored, ΔH_{ls} is the heat of fusion at the phase change temperature T_{PC} , C_S is the specific heat of the material in solid state and C_L is the specific heat of the material liquid state.

Latent heat thermal energy storage is particularly attractive due to its ability to provide high-energy storage density per unit mass in quasi-isothermal process. This means that in a specific application where the temperature range is important, for instance in transport of sensitive temperature products, the use of PCM becomes very useful since it can store material at constant temperature corresponding to the phase-transition temperature of the PCM.

3.4 Model others industrial furnaces components

A schematic view of industrial furnace is showed in Figure 13 where there are some basic components: i) The combustion chamber is an isolated area where heating process is carried out; ii) Air input is the system in charge of feeding combustion process through a pipeline; iii) Chimney is the conduct or structure where fumes move from inside of the chamber to the outside atmosphere; iv) Load is the target material that heating or melting process is carried out; v) Gas burner is the system that generates a flame with gaseous fuel and oxygen; vi) Air input is the conduct in charge of feeding combustion process.

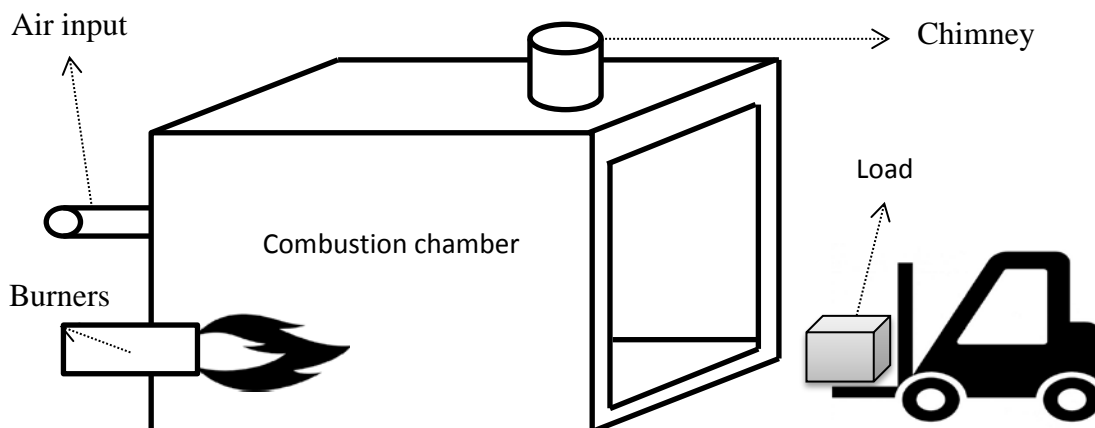


Figure 13. Elemental volume for one-dimensional heat conduction


	Document:	D6.1 User Requirements Specification for the MCS	
	Author:	Tecnalia	Version: 2
	Reference:	D6.1 VULKANO G.A. 723803	Date: 25/05/17

Table 1 shows equivalent thermal representation of the most common components of an industrial furnace.

Table 1. Basic thermal components to model an industrial furnace


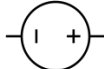




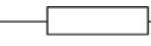
BASIC COMPONENTS OF INDUSTRIAL FURNACE			
Air input		Resistance = $\frac{1}{G_{in} \cdot C_p}$	G_{in} = input mass flow rate C_p = air specific heat
		Voltage source = θ_{in}	θ_{in} = input air temperature
Burners		Current = q_i	q_i = heat flux
Load		Capacitor = C_L	C_L = thermal capacitance of the load
		Resistance = R_{LC}	R_{LC} = thermal resistance between the load and the chamber
Combustion chamber		Capacitor = C_C	C_C = thermal capacitance of the chamber combustion
		Resistance = R_{CA}	R_{CA} = resistance of the walls between chamber and the ambient

Figure 14 shows an example of thermal equivalent model of combustion chamber wall using the element described on Table 1 where T_{Out} is the external temperature of Air; T_{In} is the internal temperature of Air in combustion chamber; T_{Wall} is the internal temperature of wall; $R_{Out-wall}$ is the equivalent thermal resistance of conduction and convection between external air and internal wall; $R_{Wall-In}$ is the equivalent thermal resistance of conduction and convection between internal wall and combustion chamber atmosphere; C_{Wall} is the thermal capacity of the wall.

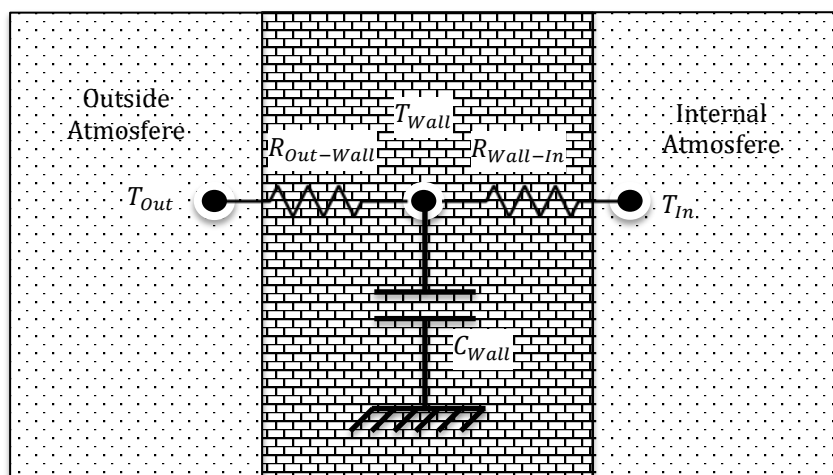


Figure 14. Elemental heat exchanger Blocks diagram

4 CONTROL FOR INDUSTRIAL FURNACES

Control theory implemented in industrial furnaces do not differs from others systems. Control theory can be classified depending on the complexity of the system, such as Classical control theory, for simple system using basic tools, and new approaches, for non-linear systems using complex algorithms.

This section is organized as follow: Section 4.1 describes classical control theory aspects, section 4.2 outlines modern control theory, and section 4.3 depicts robust control as a branch of modern control theory.

4.1 Classical control theory

Classical control theory is a branch of control theory that uses elementary control concepts to design a controller. Dynamic systems with sensors, actuators and controller are represented in Laplace domain such as Figure 15 where $X(s)$ is the setpoint or reference value enter as an input, $Y(s)$ is the measured of output value, $Z(s)$ is the output value and $D(s)$ is the disturbance or interruption of peaceful condition.

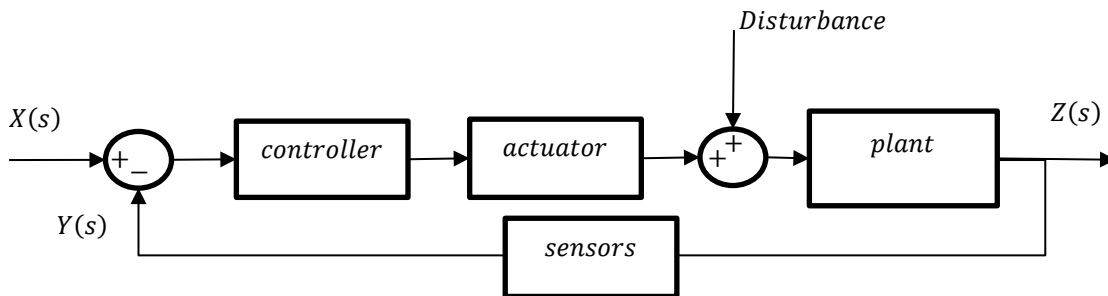


Figure 15. Elemental volume for one-dimensional heat conduction

These dynamic systems should satisfy various characteristics. The first constraint feature deals with relationship between the input and the output of the system must be linear. The second feature of the dynamic system is related to the invariance over time (an input now comparison with another x seconds from now generates an identical output except for an x seconds delay).

The concepts of time domain and frequency domain are related to Laplace transform in case of continuum time systems and Z transform in discrete time systems. Figure 16 shows these concepts.

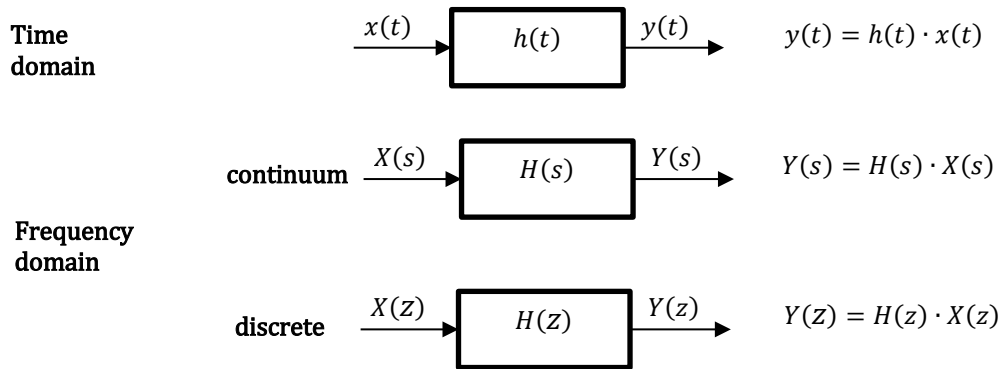


Figure 16. Relationship between the time domain and the frequency domain

Normally, these types of systems are divided into Single-Input Single-Output (SISO) systems and controllers (PI, PID, or lead-lag) are independent calculated.

The tools for controllers design include root locus, the Nyquist stability criterion, the Bode plot, the gain margin and phase margin.

4.2 Modern control theory

Modern control theory covers linear and nonlinear systems. On the one hand, linear systems are usually defined by linear differential equations with constant parameters over time. Controllers are calculated by techniques such as Laplace transform, Fourier transform, Z transform, Bode plot, root locus, and Nyquist stability criterion. Controllers are defined by the description of the system response by means of bandwidth, frequency response, eigenvalues, gain and resonant frequencies.

On the other hand, nonlinear systems are often defined by nonlinear differential equations. Controllers are calculated by limit cycle theory, Poincaré maps, Lyapunov stability theorem, and describing functions. Nonlinear systems can be linearized by transformed into a linear system by means of linear techniques such as linear approximation with Taylor's theorem.

4.3 Robust control

Robust control is a set of control design methods that take into account imprecise parametrization, disturbances events and uncertainty in general to design robust controllers to achieve high performance and right stability under bounds considered. Theory of robust control started in 80's and is still active today. One method of robust control is Quantitative Feedback Theory first time introduced by Isaac Horowitz (Horowitz & Sidi 1972).

4.3.1 Uncertainty quantification

There are two types of uncertainty: i) forward propagation of uncertainty where errors are propagated to forecast the uncertainty response. ii) inverse assessment of uncertainty where parameters are calibrated using data sets.

Normally, in the process of modelling complex systems, no uncertainty is considered and optimal settings can be implemented at the precise values. These assumptions are distant from real behaviour of physical systems. Although identifying the sources of uncertainty that affect to the complex system is a laborious task and takes huge time to reduce it, this uncertainty can be modelled.

One way to express parametric uncertainty of one parameter 'p' is by means of interval arithmetic such us error as a result of disturbances coming from process.

$$p_{min} \leq p \leq p_{max} \quad (13)$$

Where p_{min} and p_{max} are the minimum and maximum value respectively.

Two techniques of inverse regression-based algorithms to reduce dimensionality of uncertainty quantification problems are proposed and compared with the classic Monte Carlo technique, obtained better convergence results (Li et al. 2016).

Tuning the parameters of a mathematical model for a horizontal continuous annealing furnace is carry out by a nonlinear constrained least-squares algorithm. It is shown that the model predictions agree well with measurement data in steady-state and transient conditions (Zareba et al. 2016).

4.3.2 Performance specifications

The output must lie between specified upper and lower bounds. There are specifications in time and frequency domain. On the one hand, Figure 1 shows some bounds specification in time domain.

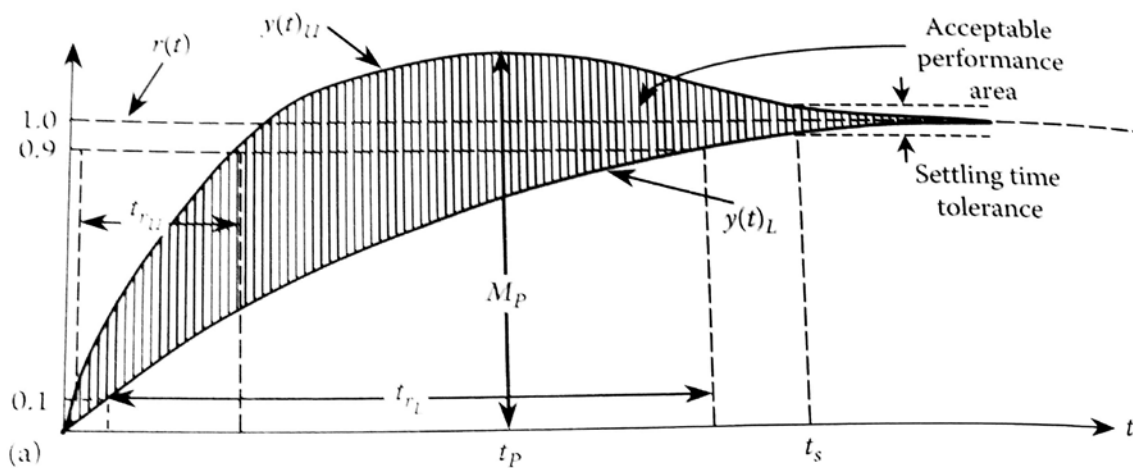


Figure 1: time domain response specification

On the other hand, Figure 2 shows some bounds specification in frequency domain.

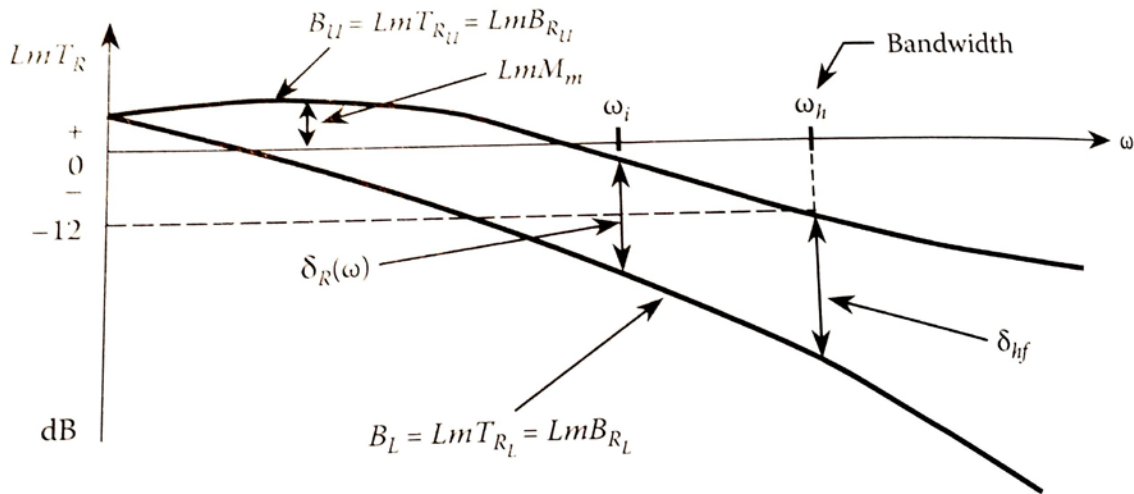


Figure 2: frequency domain response specification


5 CHALLENGES FOR M&Cs IN INDUSTRIAL FURNACES

Although industrial furnaces require a huge amount of energy to accomplish the process, energy saving strategies can be implemented in new and existing industrial furnaces by retrofitting actions: I) Using Phase Change Materials (PCMs) to energy recovery for combustion air preheating, charge preheating and supplying energy to other upstream and downstream processes. II) Using New advanced refractories with improved heat resistance materials to reduce heat losses working at different temperatures. III) Using burners for co-firing natural gas and syngas coming from biomass gasification and off-gases produced in the manufacturing process, additionally reducing CO₂ emissions. IV) Designing new strategies of Monitoring and Control System (M&CS) to increment the overall efficiency. V) Holistic in-house predictive tool.

Two main scenarios are considered from different relevant industries. The first one is a continuous melting furnace in the ceramic sector, while the second case is a preheating furnace in the steel sector.

5.1 Using Phase Change Materials (PCMs) for energy recovery

Melting and heat treating process of industry furnaces require a huge amount of energy and, in some of them, energy is dissipated by the off-gas. The high variability of temperatures and flows, and the high concentration of dust, which characterize the production process, make the adoption of current energy recovery solutions quite difficult, both from the technological and the economical perspective. The use of Phase Change Materials (PCMs) for energy recovery within combustion air preheating and charge preheating, enables to supply energy to other upstream and downstream processes. PCMs reduce the variability of off-gas temperatures, in order to achieve an efficient energy recovery (Nardin et al. 2014).

	Document:	D6.1 User Requirements Specification for the MCS	
	Author:	Tecnalia	Version: 2
	Reference:	D6.1 VULKANO G.A. 723803	Date: 25/05/17

PCMs provide higher heat storage capacity and more isothermal behaviour during charging and discharging compared to conventional heat storage system.

The main heat transfer difficulties in energy recovery with PCMs are the heat transfer moving boundary problems. These problems turn round melting and solidification processes with mixtures or impure materials. On the one hand, melting and solidification occurs at a single temperature when the substance is pure. On the other hand, melting and solidification processes take place over a range of temperatures. This is normally happened with mixtures or impure materials (Zalba et al. 2003). The creation of a new control should take into consideration the behaviour of phase change materials in order to maximize efficiency.

5.2 Using New advanced refractories

New advanced refractories with improved heat resistance materials to reduce heat losses working at different temperatures are investigated inside VULKANO. Refractory maintenance and refractory efficiency are the main issues from the monitoring system point of view.

The most effective method for monitoring refractory integrity is through vessel skin temperature measurements. This task is typically performed by contact thermocouples or infrared temperature sensors or thermographic cameras. The advantages and disadvantages of different technologies to measure temperatures are explained in section 2.2.1 of this document.


There are tools that use different algorithms and various techniques to detect failures and estimate life cycle of refractory with data gathered from thermal sensor. A condition monitoring tool of an industrial furnace refractory based on e-maintenance and industry 4.0 concepts is shown in (Fumagalli et al. 2016).

5.3 Using burners for co-firing

New furnaces include burners of co-firing natural gas and syngas coming from biomass gasification and off-gases produced in the manufacturing process. Using these gases reduces the CO₂ emissions.

The main problem of co-firing burners is the limited biomass level, around 5% by mass. Higher levels of substitution sometimes lead to burner instability and other issues. The monitoring and control of combustion systems can increase the proportion of gasses being combusted by optimal setpoint parameters (Valliappan et al. 2016). In order to develop an accurate combustion, some sensors need to be installed to gather information about flame features. This information is mainly flame stability, excess air level, NO_x and CO emissions. A furnace monitored with photodiodes sensors to flame characterization is shown in (Valliappan et al. 2012).

There are experimental papers that investigate flame features due to importance of accurate monitoring on co-firing burners. To assess the stability of flame in terms of its colour, geometry, and luminance is proposed in (Sun et al. 2015), where experimental results obtained demonstrate

	Document:	D6.1 User Requirements Specification for the MCS	
	Author:	Tecnalia	Version: 2
	Reference:	D6.1 VULKANO G.A. 723803	Date: 25/05/17

the effectiveness of the methods and the importance of maintaining a stable flame for reduced NOx emissions.

5.4 New strategies of Monitoring and Control System

The new strategies of Monitoring and Control System can be divided into monitoring issues and control aspects. On the one hand, monitoring issues are concerned about precise balance between accuracy, reliability, maintainability and cost to achieve an acceptable global solution of observation and inspection. Main challenges are related to the technology used into cyber physical systems sensors to gather physical measurement in severe situations in an accurate way. To measure some parameters requires high technology due to the difficulty to install and maintain a sensor in harsh conditions such as inside a chamber where the temperature is extraordinary high.

Other monitoring challenges reside on the difficulty to measure unreachable spots with severe temperatures. One example is a burden inside a chamber of industrial furnace; although ultrasonic sensors are capable to measure internal temperatures of an element, transducers used needs physical contact with the element and tolerate high temperatures or even resist direct flame.

On the other hand, challenges in control systems come from using advanced control algorithms and strategies into nonlinear complex systems that require interaction between Multi-Input and Multiple-Output (MISO). Same of the main branch control strategies are adaptive controls and robust control. Robust control controller is a fixed controller designed for models with uncertainly or indefinite dynamics. An adaptive control controller is a flexible controller that parameters fluctuate as a model changes. shows a nonlinear plant with a set of robust controller (A, B ,...,and Z).

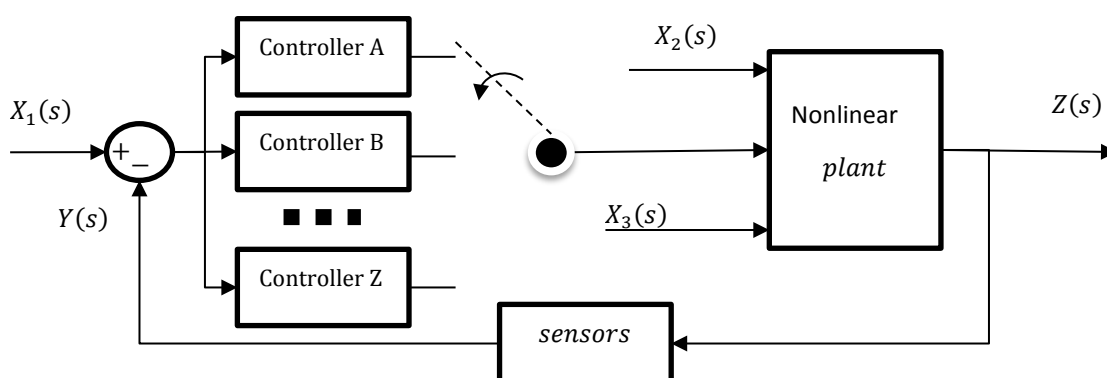



Figure 17. Nonlinear robust control with parametric uncertainty

Another set of methods used for controller design are metaheuristics algorithms. These algorithms find optimal parameters set into controllers in a balance or compromise between computational time used and goodness of solution (Upton et al. 2013). Also, hybrid strategies can improve conventional approach (González-González et al. 2014).

	Document:	D6.1 User Requirements Specification for the MCS		
	Author:	Tecnalia	Version:	2
	Reference:	D6.1 VULKANO G.A. 723803	Date:	25/05/17

The main parameters to be controlled are: i) Fuel flow rates or heat inputs to the furnace; ii) Combustion air flow rate or air/fuel ratios; iii) Combustion air temperature; iv) Furnace temperature(s); v) Furnace exit gas composition; vi) Furnace exit gas temperature; vii) Feed rate of raw material to the furnace; viii) Physical and chemical composition of raw material to the furnace; ix) Product exit temperature.

5.5 Others

Improvements over industrial furnaces process refer to several items such as reducing the heating cost per unit finished, decreasing maintenance cost by means of better predictive maintenance policy or reducing amount of rejected pieces as a result of better control process temperature. Although there are various ways enhanced, energy improvement is the aspect that takes extra attention due to fuel consumed is the greatest cost.

The main objectives to be achieved can be listed as follows: i) Maximising furnace production capacity; ii) Ensuring satisfactory product quality; iii) Minimising fuel consumption; iv) Minimising emissions; v) Controlling furnace warm-up; vi) Enabling smooth change-over between different products.

6 M&Cs LESSON LEARNED

The main lessons learned in industrial furnaces are divided into steel, aluminium and ceramic sectors, corresponding to sections 6.1, 6.2 and 6.3 respectively. The information has been provided by the end-users VULKANO: Valji, ASAS and Torrecid respectively.


6.1 Steel sector

Although there is currently a lack of contributions on lessons learned from steel sector, the preheating steel process is widely studied by scientific papers. These lessons learned are structured by the items below:

Monitoring heat losses. The most common heat losses are located around doors, jamb, sills, tramp air, cooling losses, Wall Losses, refractory evolution, losses through conveyor equipment and other gaps losses. Most of them are not properly monitored.

Monitoring temperatures. To monitor correctly the preheating process, different temperature sensor locations are needed. To avoid calibration issues, a correct maintenance procedure is needed.

Monitoring and control air/gas Ratio: To avoid incomplete combustion emissions with high CO emissions, a CO meter analyser is needed.

	Document:	D6.1 User Requirements Specification for the MCS	
	Author:	Tecnia	Version: 2
	Reference:	D6.1 VULKANO G.A. 723803	Date: 25/05/17

Monitoring and control furnace gases exhausted: Since exhausted gases carry valuable energy that could be used to preheat air, gas, and loads, PCMs will be used to recover temperature and to maintain certain temperature constantly.

Monitoring and control Furnace Pressure Control: to prevent out-leakage of unburned air, a pressure meters is useful to regulate burners.

6.2 Aluminium sector

Lessons learned from aluminium industrial furnace are condensed into the paragraphs below:

Monitoring heat losses: Although the heat loses is an important aspect due to economic impact in furnaces companies, they are not monitored in aluminium furnaces. The VULKANO aluminium partner, ASAS, gathers an experience over the years and realises that the main and most common heating losses happen around furnace door and close to burner hole. At the moment, this issue is not treated properly.

Monitoring temperatures. An adequate location of temperature sensors is crucial to monitoring heating and melting process. All the temperature sensors used are thermocouples. In heating process, one sensor is located near the burners to measure surface of the billet temperature. In melting process, there are two thermocouples inside of the furnace for calibration, maintenance and production issues. One of them is located at furnace ceiling to control the gas temperature inside of the furnace to prevent of the refractory damages; in this case, this sensor must be less than 1000°C. The second one is located at furnace bath wall to measure melted aluminium.

Burners control. The on/off action of burners actuators are controlled by using temperatures measures from sensors described above.


Monitoring and control air/gas Ratio: Although high CO ppm emissions are inefficient due to incomplete combustion emissions, meaning that all heat is not released, ASAS partner does not have online gas analyzer system or gas monitor system. Instead of that, combustion control is performed by using a prefixed air/gas ratio. In this case, this ratio is about 10.

Monitoring and control furnace gases exhausted: exhausted gases carry valuable energy that could have been used to preheat air, gas, and loads. At the moment, recuperator and re-generative burner system are installed to recover exhaust gas as preheat air or billet.

Monitoring and control Furnace Pressure Control: To prevent out-leakage of unburned air, a gas analyser device is needed. Gas analyser devices will supply the correct values, meaning needed air, needed natural gas and correct set point or ratio. Although, pressure sensor shows another combustion parameter, it is not installed at the moment.

6.3 Ceramic sector

Lessons learned from aluminium industrial furnace are described within the paragraphs below:

	Document:	D6.1 User Requirements Specification for the MCS		
	Author:	Tecnalia	Version:	2
	Reference:	D6.1 VULKANO G.A. 723803	Date:	25/05/17

Heat losses: All actions aligned to reduce heat losses such as increase isolation or reuse residual heat into another process contribute to a better safe environment. The most common heat losses in ceramic smelters are coming from frit falling into the water, molten glass, heat loss around draining hole, and exhaust gases. On the one hand, an important heat is dissipated when frit is quenched into the water due to heat water is not used by other process. Also, water temperature and flow is not currently controlled by any meter. This process could be optimized. On the other hand, the smelters are built using insulation fibre and refractory, so the heat coming out through the walls is reduced. Furthermore, there are not doors or windows to improve insulation and increase energy efficiency.


Monitoring temperatures: Monitoring the temperature depends on application. In the case of ceramic smelter, the temperature measurement is carried out close to the molten glass, at the raw material feeding place, at the middle, at the exit of frit and in the exhaust of fumes. No measurement is carried out outside. Reducing external furnace temperature during the melting process makes the system more energy efficient. This energy efficiency resides in material used to cover combustion chamber; therefore control of this parameter would be useful, as well as to improve insulation. Calibration and maintenance is not an issue since they can be extracted from the holes made in the chamber. Thermocouples are protected.

Monitoring and control air/gas Ratio: The combustion in ceramic smelter is made normally by natural gas (NG) with air. The flow rate of NG is 165 Nm³/h and the air has a 10 to 15% excess. Additionally, the air is preheated up to 600 °C thanks to the energy recovery system installed in the flue gases (1300 °C – but a particle filter is needed beforehand). Additionally two other oxy gas burners are located within the furnace. The burners do not work in stoichiometric ratio, since also flame length is of importance. Here a better view of the length of flame would be of interest.

Monitoring and control furnace gases exhausted: In ceramic smelter, exhaust gases are used to preheat combustion heat. VULKANO will use them to heat PCM and improve heat transfer. Other heat recovery systems could be used for drying the frits at the exit of furnace (in some cases frits have to be grinded and they need to be dry) and also to feed spray drier or turbo driers where ceramic slip is spray dried.

Monitoring and control Furnace Pressure Control: In ceramic smelter pressure is controlled by inflow air flow to achieve an optimum melting atmosphere. These ideal conditions prevent out-leakage of unburned air.

Other issues in Monitoring and control: There are other issues to take in considerations **i) Measurement, monitoring and control the furnace thermal expansion:** Furnace thermal expansion is due to the huge gap between maximum temperature levels in melting process (1500°C) and minimum temperature in idle state or maintenance state (current ambient temperature). Strain gauge sensors are a common solution used to measure small structural movements. The objective to monitor those thermal expansions lies in alerting structural failure and corrects structural failures before they occur. **ii) Measurement and monitoring the external furnace temperature:** Reducing external furnace temperature during the melting process makes the system more energy efficient. This energy efficiency resides in material used to cover

	Document:	D6.1 User Requirements Specification for the MCS		
	Author:	Tecnalia	Version:	2
	Reference:	D6.1 VULKANO G.A. 723803	Date:	25/05/17

combustion chamber. Better thermal features of this material reduce the quantity of heat dissipated and improve the efficiency of the process. **iii) Parallel control of the operation of the lateral burner:** Lateral burner and main burner use separated control loops. A control combination of lateral burner and main burner increases the energy efficiency by reducing heat losses.

7 USE CASES DESCRIPTION

There are two main use cases: The first one is ceramic melting furnace (Torrecid) showed on section 7.1; and the second one is steel pre-heating furnace (Bosio&Valji) showed on section 7.2.

7.1 Ceramic melting furnace (TORRECID)


The complete lists of sensors implemented in VULKANO Ceramic Furnaces as well as the demonstrator description are shown in deliverables D2.1 & D2.2. However, the main current technical characteristics of operation and control in Torrecid furnaces are summarized on this section 7.1.

This section is organized as following: furnace technical characteristics are shown in section 7.1.1; process description is described in section 7.1.2; section 7.1.3 depicts the most important furnace control issues; and finally, the project development aspects related to monitoring and control are detailed in section 7.1.4.

7.1.1 Furnace technical characteristics

The main furnace technical characteristics are showed in the items below.

- **Industrial Sector:** Ceramic / Non-ferrous
- **Size:** 6,5 m x 2 m x 2 m
- **Nº energy sources:** 1
- **Type of fuel/s:** Natural Gas
- **Production capacity:** 800 kg/hour
- **Energy consumption:** 1952 kWh
- **Operating Temperature:** 1500 – 1580 °C
- **Combustion Excess Oxygen:** No oxygen enrichment
- **Excess air:** from 10% to 15%
- **Number and type of burners:** two type of burners. Main burner gas-air or gas-oxygen, the other one oxygen-gas side
- **Feeding material to be melted:** Feeding by worn screw
- **Frits outflow:** only way out of frits by overflow
- **Process type:** continuous

	Document:	D6.1 User Requirements Specification for the MCS		
	Author:	Tecnalía	Version:	2
	Reference:	D6.1 VULKANO G.A. 723803	Date:	25/05/17

- **Refractory materials:** electro-AZS, alumina-silica brick, insulating brock. Absence Silicon carbide particles and aluminium metal. No pre-treatment of the mixture.

7.1.2 Process description

The process is continuous in the furnace, where the feeding material is melted at 1500 °C to 1580 °C (depending on the raw material) and goes out by overflow. The feeding flow rate is 800 kg/h.

The combustion is made normally by natural gas (NG) with air. The flow rate of NG is 165 Nm³/h and the air has a 10 to 15% excess. Additionally, the air is preheated up to 600 °C thanks to the energy recovery system installed in the flue gases (1.300 °C – but a particle filter is needed beforehand). The energy recovery system has reached a maximum technology performance, and although some attempts to increase energy recovery have been done, it has not been successful. Currently, gases are thrown at high temperature to the atmosphere. Frit melting furnaces produce waste heat at 800-1000 °C, gases that are loaded with dust and undergo treatment by dust collectors. Previously due to the high temperatures cooling is required. Waste exhausts consist on steel panels covered internally with insulating fibber. Main problems are corrosion through the insulating fibre and clogging with dust and ashes.

Refractory materials are key materials in ceramic frit smelters. Due to the corrosion level about 1.5 kg of refractory /ton of molten frit, furnaces have to be rebuild every 3-4 years, while parts subjected to higher corrosion and wear like frit exhaust are replaced once a year. In the case of frit production high wear resistant materials like SiC cannot be used due to contamination issues. Attempts to improve lifetime of refractory include cold wall technology, which means cooling with water the outside of furnace, promoting a frozen glass layer or high viscous glass layer. Nevertheless, corrosion problems caused by water and condensation limit the use and only it is applicable to low melting glasses. Downstream the process, the melted material is thrown to a water tank, in which it becomes vitreous, necessary for the product features. This material is following milled to reach required particle size, which is between 200 and 600 micrometres. Heat consumption is given, depending on the material, before or after the milling process, to ensure complete drying of the product to continue the process.

The process of the ceramic furnace (upstream and downstream) is described in Figure 18.

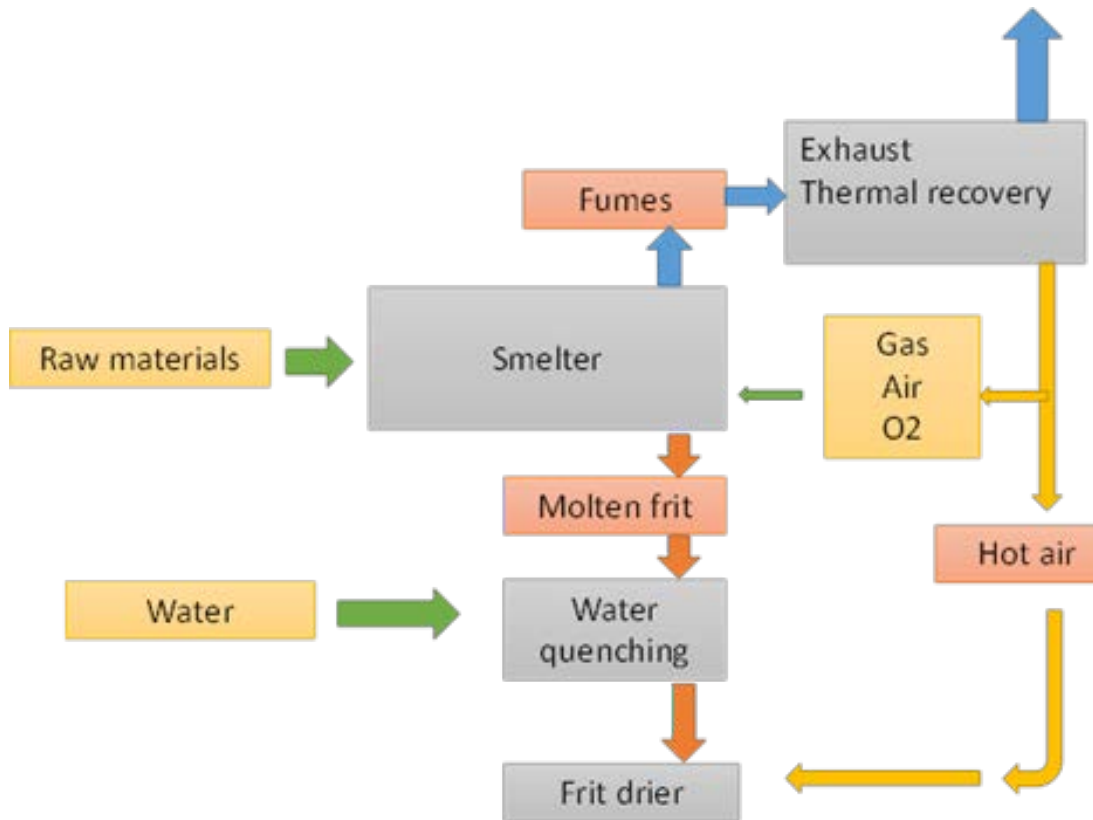


Figure 18. Process flow chart of VULKANO ceramic furnace (TORRECID).

Estimation of process efficiency: 40% to 45% gas-air furnace. 75% to 80% gas-oxygen furnace

Gas cleaning techniques: Filtration of dust particles by filter

Heat recovery equipment

- *Output stream on which it is done:* Heat recovery to preheat the combustion air from the combustion fumes.
- *Type equipment and number:* 2 equipment per oven; 1 heat recovery for combustion air, 1 heat exchanger to cool fumes before the filter.
- *Current use of recovered heat:* Preheating of combustion air, the heat exchanger expels air to atmosphere.

Flows upstream the process: mixture of raw materials to be melted

Flows downstream the process: cooling the molten material with water, follow by milling wet or dry.

7.1.3 Furnace control

There are various sensors with diverse technologies required to measure different physical variables; some of them are listed below:

- Temperature measurement by optical pyrometer.

	Document:	D6.1 User Requirements Specification for the MCS	
	Author:	Tecnalia	Version: 2
	Reference:	D6.1 VULKANO G.A. 723803	Date: 25/05/17

- Measurement of the furnace variables by electronic transducers.
- PLC process control and SCADA control.
- Optical measurement of excess oxygen in the furnace.
- Spot metering gas emissions, according to the current regulations.

7.1.4 Project developments with impact on the M&CSs

PCMs recovery system. This solution will be applied at TRL 7. The use of the PCMs will be able to overcome the current technological barrier given in the energy recovery system from flue gases for air preheating, which currently permits 600 °C temperature to be achieved in the air. The first simulations performed at proposal stage states that, using PCMs and therefore latent heat instead of sensible, would increase the efficiency of the recovery system and get between 800 and 820 °C in the entrance air. These calculations have considered the particles filter that is necessary to clean gases and that is currently working in the plant. TRL 7 will be achieved here.

New refractory materials. New refractory materials will change the thermal behaviour of the furnaces. It is important to characterize the influence of new refractory materials in order to adapt control systems to the new behaviour of the system. The main objective of monitoring refractory materials resides on maintenance and life cycle management; specifically, deciding the right moment to perform maintenance actions in order to achieve an optimum balance between heat losses due to deteriorated refractory and the cost of installing new refractory materials.


New control system. This solution will be tested at TRL 6. The new control system identified as part of WP6 activities by TECNALIA will be run / operated in parallel to the current one, comparing the control outputs and running simulations in parallel. Eventually, if risk analysis recommends it, the furnace operation could be forced by introducing specific values to control variables according to the ones provided by the new control system rather than the current one, in order to evaluate and compare, and get more accurate results closer to TRL 7. Nevertheless, the reasonable objective in this aspect is to guarantee TRL 6 and, if possible VULKANO will go beyond.

Safety issues related to those M&CSs parts (hardware and software) that are assigned to provide safety functions (safety-related parts of control systems, SRP/CS).

7.2 Steel pre-heating furnace (Valji)

The complete list of sensors implemented in VULKANO steel furnaces as well as the demonstrator description are developed in deliverables D2.1 & D2.2. However, the main current technical characteristics of operation and control in Valji furnaces are summarized on this section 7.2.

This section is organized as follows: Furnace technical characteristics are described in section 7.2.1; Process description is depicted in section 7.2.2; the most important furnace control issues are listed in section 7.2.3, and finally, the project development aspects related to monitoring and control are detailed in section 7.2.4.

	Document:	D6.1 User Requirements Specification for the MCS	
	Author:	Tecnalía	Version: 2
	Reference:	D6.1 VULKANO G.A. 723803	Date: 25/05/17

7.2.1 Furnace technical characteristics

The main furnace technical characteristics are showed in the items below.

- **Industrial Sector:** Steel
- **Type:** Moveable hearth (PP-KPV 58/400)
- **Furnace construction dated:** 1988
- **Size:** 3,6 m x 6,5 m x 2,5 m
- **Nº energy sources:** 1
- **Type of fuel/s:** NG + Syngas (from biomass - VULKANO)
- **Energy consumption:** 135 Nm³/hour (Natural Gas)
- **Pressure in conduits:** 4 bar (NG)
- **Operating Temperature:** From 100°C to 400°C
- **Maximum Permitted Temperature:** 450°C
- **Exhaust gases Temperature:** 200°C
- **Tº distribution:** 20°C (measured in the work piece, after 8h diagram)
- **Combustion Excess Oxygen:** air-gas ratio 1,1 (volO₂ in flue gas=1,72%)
- **Number and type of burners:** 3 (option 5) x 450 kW
- **Type of burners:** BIO, Kromschröder
- **Position of burners:** At side walls
- **Load:** Moulds for ingots
- **Load weight max.:** 75 tons
- **Maximum dimensions of load:** 1800mm x 4700mm
- **Isolation:** Rock wool 250mm
- **Emissions:** NO₂ = 3000g/h / SO₂ = 970 g/h / CO = 1440 g/h
- **Refractory materials:** ceramic fibbers on walls, doors and roof
- **Material of moulds:** C 22, 1 – 2 moulds at the same time, 3 to 7 moulds per day.
- **Mass of the moulds:** 15–38 tons/mould (18–20 tons/mould in average)
- **Type of process:** Batch process
- **Estimation of process efficiency:** 70%
- **Exhaust gases:** Draining from furnace by natural draft of chimney
- **Heat recovery equipment:** None
- **Structure:** Furnace's case, door and moveable hearth are made of steel profiles and sheet metal from carbon steel. Door opens vertically.

7.2.2 Process description

The load is placed in the oven where it is heated for 2 hours arising to 70 °C. Then the mould is taken from the oven and placed in a pit for the molding of the final cores. Mould is brushed and formed. The whole process takes from 2 to 4 more hours, depending on the size of the mould. When this procedure is completed the mould is returned to the furnace. The temperature of the mould in this moment drops to approx.20°C. Following the mould is heated up to 120°C during at

least 3 hours. The mould is taken again out of the furnace to coat the final core from 3 to 5 times depending on the quality of the cylinder. Coating takes from thirty minutes to one hour, during this time the temperature falls about 10°C. After this, the mould is loaded again into the furnace turned by 180° around the horizontal axis and in this position is heated to 220°C during 3 more hours. After this preheating process the mould remains for one hour with the furnace switched off and closed in order to achieve the equalization of the temperature throughout the mould.

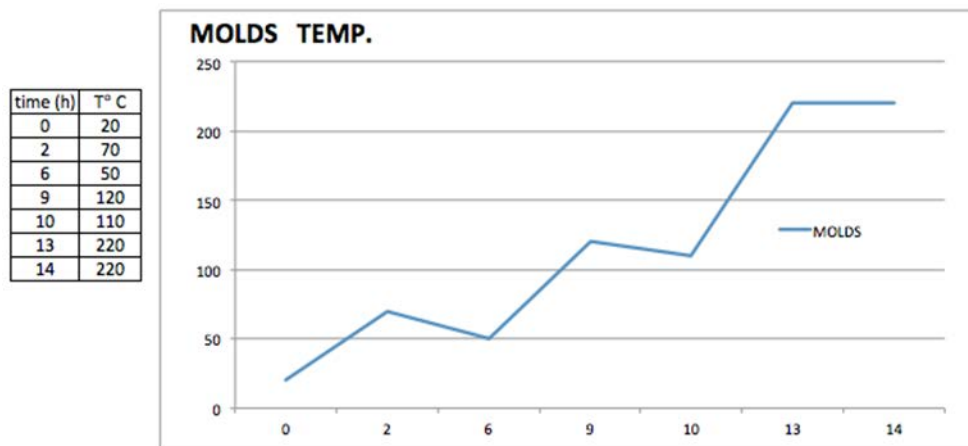


Figure 19. VSF - Pre-heating process


7.2.3 Furnace control

There are various sensors with diverse technologies required to measure different physical variables; some of them are listed below:

- **Type:** PLC Siemens
- **Three-phase current:** TN-C-S 3 x 400 V / 50 Hz
- **Regulations loops:** Temperature and pressure
- **Measures:** furnace temperatures, security thermocouples, gas consumption and load temperatures
- **Description:** Regulation of the temperature and controlling of all other functions is made by PLC. Communicational panel is in the forefront of the main control cabinet. Equipment for controlling and regulation of the furnace are place into two cabinets near the furnace. The regulation of the temperature is carried out in several zones on the furnace. Safeguarding against the overload of the maximum temperature is carried out by an independent thermocouple and a safety regulator.

7.2.4 Project developments with impact on the M&CSs

Complementary source of energy for the NG. Co-firing of NG and syngas coming from biomass gasification is proposed. This solution will be applied at TRL 7. Two strategies will be pursued. The first is the co-firing in different burners, so that additional burners will be added to the furnace for low-calorific syngas (calorific value of syngas is lower than NG). Complementarily, the other

	Document:	D6.1 User Requirements Specification for the MCS	
	Author:	Tecnalia	Version: 2
	Reference:	D6.1 VULKANO G.A. 723803	Date: 25/05/17

strategy will be the combination of syngas and NG in the same pipe feeding the burner, which entails a challenge. Gas stations will be installed to measure and control consumption.

PCM recovery system: will be applied at TRL-6. The PCM system will not be installed at TRL 7, in contrast to the ceramic furnace, in this case two different initial approaches were envisaged in the proposal. The first one is the use of the PCM for better integration upstream and downstream. A suitable heat source (600 °C) has been identified close to the real operating furnace, which could be suitable for fuel / air preheating prior to combustion, or use in the gasification unit. Thus, PCM specific performance tests will be done in TECNALIA or VALJI if possible on how the materials will act at those temperature levels, and based on that, a simulated solution for the integration of the recovery system will be done. The retrofitted furnace will be situated separately, which obstructs higher TRL achievement. The second approach, able only to be tackled theoretically based on TRL 5-6 tests performed to the PCMs, implies a higher innovation approach, and it is how the use of PCM inside or outside the furnace can improve the energy performance in batch processes such preheating, where doors are opened and products released slowly, with high losses. This solution would be suitable only for batch preheating processes where there is no melting product. For that reason and the higher viability observed along the project, the approach one is being analyzed deeply.


New refractory materials. New refractory materials will change the thermal behaviour of the furnaces. It is important to characterize the influence of new refractory materials in order to adapt control systems to the new behaviour of the system. The main objective of monitoring refractory materials resides on maintenance and life cycle management; specifically, deciding the right moment to perform maintenance actions in order to achieve an optimum balance between heat losses due to deteriorated refractory and the cost of installing new refractory materials.

New control system. This system will be implemented in the PLC platform that the furnace will have with the identified as part of WP6 activities. It will take the measures from the equipment already identified and will apply control schemes in temperature to control gradient within the furnace (different temperature levels may be need in different areas of the furnace for the moulds), pressure and co-firing operation. This system will be tested at TRL 7 as it will be operational in the furnace.

Safety issues related to those M&CS parts (hardware and software) that are assigned to provide safety functions (safety-related parts of control systems, SRP/CS).

8 USERS REQUIREMENTS SPECIFICATIONS FOR THE MONITORING AND CONTROL SYSTEMS (URS-M&CSs)

All the User Requirement Specification for Monitoring and Control Systems (URS-M&CSs) are divided into two sections, according to the two furnaces to be developed by the project: URS-M&CS for the ceramic furnace on section on section 8.1 and URS-M&CS for the steel furnace on section 8.2.

	Document:	D6.1 User Requirements Specification for the MCS		
	Author:	Tecnalia	Version:	2
	Reference:	D6.1 VULKANO G.A. 723803	Date:	25/05/17

8.1 Ceramic melting furnace (TORRECID)

This section, of user requirement specifications for ceramic melting furnace, is organized as following:

- Section 8.1.1: user requirement of materials flow;
- section 8.1.2: the most important equipment and sensors needed;
- Section 8.1.3: requirement to achieve on energy efficiency issues;
- section 8.1.4: environment aspects to take into account;
- section 8.1.5: safety matters;
- section 8.1.6: others requirements;
- section 8.1.7.: finally, a summary of monitoring and control systems for VULKANO ceramic furnaces.

8.1.1 Materials flow

The main Torrecid requirement specifications for monitoring and control systems related to materials flow are summarized in the paragraphs below.

Measurement, monitoring and control the input of raw material and final product. Input raw material flow is not measured currently in TORRECID furnaces. Monitoring this parameter allows to improve the over existing smelter control by reducing the difference between temperature setpoint and temperature monitored inside the combustion chamber. One way to monitor this parameter is by measuring the weight of the hopper over. The hopper is supported by load cells. The measurement system consists of continuously monitor the weight of the hopper over the kiln feeder. The calculated flow of raw material is compared to the set flow and the difference is used to calculate the action signal by means of a controller.

Measurement, monitoring and regulation the temperature inside smelter. Monitoring the temperature inside the smelter is useful to control the melting process. This temperature is mainly controlled by setting material flow setpoint, airflow setpoint and burners activation sequence. Implementing a smelter model to simulate the control system proposed permits improvements over existing temperature setpoint.

Measurement, monitoring and regulation of the cooling water of the finished product. Preserving the maximum temperature of cooling water of the finished product below a certain threshold by adding more new water flow into the system.

8.1.2 Equipment and sensors

Although deliverable D2.1 shows a complete list of sensors currently implemented in Torrecid furnaces, the main equipment and sensors required by Torrecid for Monitoring and control are listed in Table 2 for smelter process and Table 3 for filter process. There are two tables since the smelter process and the filter process can be considered as an independent processes. These tables show the preliminary devices to measure material movement and energy conveyed through different part of the melting process.


	Document:	D6.1 User Requirements Specification for the MCS	
	Author:	Tecnalía	Version: 2
	Reference:	D6.1 VULKANO G.A. 723803	Date: 25/05/17

Table 2. VCF - List of future sensors requirement in smelter part.

FUTURE REQUIREMENTS -SMELTER SENSORS:			
Sensor	Type	Parameter measured	Location
1	Mix sensor	Kiln feeding	Kiln feeding control
2	Camera	Frit output	At the exit of the oven
3	Camera	Frit height inside chamber	Outside the combustion chamber
4	Mix sensor	% fumes in air	In the chimney
5	Gas Analyser	Oxygen %	Smelter

Table 3. VCF - List of future sensors requirement in filter part.

FUTURE REQUIREMENTS - FILTER SENSORS:			
Sensor	Type	Parameter measured	Location
1	Mix sensor	Temperature along the filter	Diverse positions
2	Mix sensor	Mass Stream along the all pipes	Diverse positions
3	Mix sensor	% fumes in air	Outside the combustion chamber

8.1.3 Energy efficiency

URS-M&CS related to energy efficiency are listed in the following paragraphs:

Automatic introduction of the furnace heating curve. The furnace heating curve is defined before the process starts. This temperature setpoint is fixed manually over time currently in TORRECID furnaces. Automating this parameter over time is a URS. Automatic temperature setpoint improves energy efficiency by reducing losses raised due to the peaks and valleys compared to human temperature setpoint.

Measurement, monitoring and control of preheated air (flow meters) Input flow air is monitored and controlled by oxygen requirement of smelter. Maximum efficiency in temperature exchange process is achieved when input flow air is constant or with minimal flow variations.

Measurement, monitoring and control of the operation of the new PCM-based energy system (highest temperature range above 800 °C). The current energy recovery system from the facility has reached a technological limit by using commercial solutions. The new device will capture thermal energy from off-gas, increasing around 100-200°C the current temperature reached in the air flow used in the furnace combustion process. During the phases at high temperature, off-gas raises the temperature of the PCM above its melting temperature, causing the transition from the solid state to the liquid one with accumulation of the latent heat of fusion (charging process) to release this heat to the air flow.

	Document:	D6.1 User Requirements Specification for the MCS	
	Author:	Tecnalía	Version: 2
	Reference:	D6.1 VULKANO G.A. 723803	Date: 25/05/17

Measurement, monitoring and control the furnace thermal expansion Furnace thermal expansion is due to the huge gap between maximum temperature levels in melting process (1500°C) and minimum temperature in idle state or maintenance state (current ambient temperature). Strain gauge sensors is a normally solution used to measure small structural movements. The objective to monitor those thermal expansions lies in alerting structural failure and corrects structural failures before they occur.

Measurement and monitoring the external furnace temperature. Reducing external furnace temperature during the melting process makes the system more energy efficiency. This energy efficiency resides in material used to cover combustion chamber. Better thermal features of this material reduce the quantity of heat dissipated and improve the efficiency of the process.

Parallel control of the operation of the lateral burner. Lateral burner and main burner use separated control loops. A control combination of lateral burner and main burner increases the energy efficiency by reducing heat losses.

8.1.4 Environment

URS-M&CS related to environment are listed in the following paragraphs:

Include the final stage of filtration (baghouse subsystem) in the design of the new M&CS. There are two control loops that work isolated: one control for smelter and one control for filter. One future requirement is to implement a multivariable control that controls both systems as one. The goals of the control will be include reduction of airborne emission.

Measurement and monitoring furnace particle airborne emission. Monitored particle airborne emission flow allows calculation of mass balance of the system. One goal of the control system is to reduce the particle airborne emission to be friendly with the environment.


Optimization of the filtration stage and its maintenance (automatic cleaning of filters controlled by the flow rate of filtration air). Automatic detect the right time to perform a maintenance task on filters by a monitor the output flow rate. Control system gives an alert when this flow achieves a low level threshold.

8.1.5 Safety

Regarding safety issues, the demanding requirements of the Machinery Directive 2006/42/EC (MD) will fully apply to VULKANO industrial furnaces (VIF) when putting them into service for industrial production.

VIF are not required to comply with the provisions of the Directive until they are put into service (beyond the conclusion of the project). However, in order to: 1) facilitate the future CE marking and 2) avoid potential economic costs associated with future re-adaptations or modifications needed to ensure compliance with MD, the design and implementation of M&CS improvements will be aligned with the Essential Health and Safety Requirements (EHSR) of MD.

Although the application of harmonised standards is not mandatory to meet EHSR, in order to ensure presumption of conformity with MD, the improvements in M&CS will rely on harmonized

	Document:	D6.1 User Requirements Specification for the MCS		
	Author:	Tecnalia	Version:	2
	Reference:	D6.1 VULKANO G.A. 723803	Date:	25/05/17

standards (HS). When HS are not available, other technical documents will be used (e.g. international standards, European standards drafts, guidelines issued by professional organisations, etc.), although these last references do not guarantee the presumption of conformity with MD.

In this context, main URS-M&CS are related to those M&CS parts (hardware and software) that are assigned to provide safety functions (safety-related parts of control systems, SRP/CS). General safety requirements for the reduction of risks associated with TPE will be conducted with type C standard ISO 13577 “Industrial furnaces and associated processing equipment”. This standard specifies in four parts the requirements intended to be met by the manufacturer to ensure the safety of persons and property during the furnace life cycle, as well as in the event of foreseeable faults or malfunctions that can occur in the equipment. In particular, safety requirements related to M&CS and SRP/CS will take ISO 13577-4 part into account. Additional M&CS requirements not fully covered by this standard will be conducted according to standards EN 13849 and EN 62061 among other.

8.1.6 Other

URS-M&CS related to other monitoring and control issues are listed:

Diagnosis of the M&CS - control loops already implemented in the furnace to detect weaknesses that have to be solved by the new M&CS design.

The new M&CS will be run / operated in parallel to the current one, comparing the control outputs and running simulations in parallel.

Multivariable M&CS. Where they are systems with several inputs and outputs, in which one input affects multiple outputs and reciprocally one output is affected by several inputs. One example of multivariable M&CS can arise when Smelter loop and filter loop join in one complex control.

8.1.7 Summary


A summary of Torrecid requirements specifications for monitoring and control systems explained in previous sections is shown in Table 4. The first column is “Section” that identifies the item that is associated. The second one is “M&CS-USR description” that shows a brief explanation of each requirement. The third one is “priority level” that identifies the importance for future implementation by clustered into three priority levels for implementation: High priority with red colour, medium priority with orange colour and Low priority with yellow colour.

	Document:	D6.1 User Requirements Specification for the MCS	
	Author:	Tecnalia	Version: 2
	Reference:	D6.1 VULKANO G.A. 723803	Date: 25/05/17

Table 4. VCF - Summary of M&CS-USR

SUMMARY OF M&CS-USR (VCF, TORRECID)				
Section		M&CS-USR and description		Priority level
1	Raw materials flow	1	Measurement, monitoring and control the input of raw material and final product	Medium
		2	Measurement, monitoring and regulation of the cooling water of the finished product.	Medium
2	Equipment and sensors	1	New equipment and sensors are listed in Table 3 (Smelter part) and Table 4 (Filter part)	Low ¹
3	Energy efficiency	1	Automatic introduction of the furnace heating curve	Medium
		2	Measurement, monitoring and control of preheated air (flow meters)	Medium
		3	Measurement, monitoring and control of new refractory materials (PCM)	High
		4	Measurement, monitoring and control the furnace thermal expansion	Medium
		5	Measurement and monitoring the external furnace temperature	High
		6	Parallel control of the operation of the lateral burner	Medium
4	Environment	1	Include the final stage of filtration (baghouse)	Low
		2	Measurement and monitoring furnace particle airborne emission	Low
		3	Optimization of the filtration stage and its maintenance (automatic cleaning of filters controlled by the flow rate of filtration air).	Medium
5	Safety	1	In order to: 1) facilitate the future CE marking and 2) avoid potential economic costs associated with future re-adaptations or modifications needed to ensure compliance with MD, the design and implementation of M&CS improvements will be aligned with EHSR of MD . General safety requirements for the reduction of risks associated with VCF will be conducted with ISO 13577. In particular, safety requirements related to M&CS parts (hardware and software) that are assigned to provide safety functions (safety-related parts of control systems, SRP/CS) will take ISO 13577-4 part into account. Additional SRP/CS requirements not fully	High

¹ VCF: The final list of new equipment & sensors will be specified in D6.2 "Functional design specification for MCS in industrial furnaces".

	Document:	D6.1 User Requirements Specification for the MCS	
	Author:	Tecnia	Version: 2
	Reference:	D6.1 VULKANO G.A. 723803	Date: 25/05/17

			covered by this standard will be conducted according to standards listed in section 3 of this document.	
6	Other	1	Diagnosis of the M&CS - control loops already implemented in the furnace to detect weaknesses that have to be solved by the new M&CS design.	Low
		2	The new M&CS will be run/operated in parallel to the current one, comparing the control outputs and running in parallel.	Medium
		3	Multivariable M&CS	Low

Although the M&CS-USR in red colour are selected to develop the future functional design specification for M&CS in industrial furnaces (Task 6.2 and corresponding deliverable D6.2), the other M&CS-USR in orange and yellow colours will be also developed but not deeply.

Due to public dissemination of this deliverable, its content has been limited to maintain the confidentiality required by the end users. A greater detail of selected M&CSs of melting furnace of TORRECID use case will show in deliverable D6.2 due to confidential dissemination, only for members of the consortium.

8.2 Pre-heating furnace (Valji)

This section, of user requirement specifications for ceramic melting furnace, is organized as follows:

- Section 8.2.1: user requirement of materials flow;
- section 8.2.2: most important equipment and sensors needed ;
- section 8.2.3: requirement to achieve on energy efficiency issues;
- section 8.2.4: environment aspects;
- section 8.2.5: safety matters;
- section 8.2.6: others requirements;
- section 8.2.7: finally, a summary of monitoring and control systems for VULKANO ceramic furnaces.


8.2.1 Materials flow

The main Valji requirement specifications for monitoring and control systems related to materials flow are summarized in the items below.

- Monitor and control inlet and output air stream and the percentage of oxygen.
- Monitor and control flow gas to combustion.
- Monitor the load exposed to heat treatment.

8.2.2 Equipment and sensors

The main URS-M&CS related to equipment and sensors are:

	Document:	D6.1 User Requirements Specification for the MCS	
	Author:	Tecnalia	Version: 2
	Reference:	D6.1 VULKANO G.A. 723803	Date: 25/05/17

- The **measuring equipment proposed** is the traditional one in these kinds of furnaces: pressure (relative, absolute and differential), temperature at different zones of the furnace, gas flowmeter, air/fuel ratio and end positions measures.
- **Regulation** will be made by PLC. Equipment for controlling and regulation of the furnace will be placed in two main electric cabinets near the furnace. Communicational panel will be situated on the forefront of the main electric control cabinet, which is connected to the PLC.
- For the **actuators, gas equipment** and burners, pneumatics and electric drives will be considered. Finally, for control and regulation, power inverters and electrical equipment and PLC platform of Siemens (SIMATIC) will be considered.

A preliminary list of future requirement sensors is shown in Table 5.

Table 5. VSF - List of future requirement sensors.

FUTURE NEEDS FOR MONITORING AND CONTROL SYSTEM IN STEEL DEMO SITE ²			
Sensor	Type	Parameter measured	Location
1	Thermocouple	Exhaust gases	At the exit gases, in the chimney.
2	Mass Stream	Flow gases	At the exit gases, in the chimney.
3	Pressure	Air pressure	Inside the chamber
4	mix-sensor	% oxygen	Inside the chamber
5	Mass Stream	Flow air	Pipe Air flow insert
6	Thermocouple	Temperature of flow air	Outlet burner gas pipe


8.2.3 Energy efficiency

URS-M&CS related to energy efficiency are:

- **Simulation of the solution for the integration of the PCM recovery system.**
- **Monitoring, measurement and controlling co-firing of natural gas and syngas.** VULKANO will introduce co-firing in a preheating furnace at TRL 7 to substitute up to 40% natural gas in the combustion process. Experimental tests will go towards different mixture levels of natural gas and syngas in the same burner, setting an important breakthrough in this line of research. The experimental results will lead to the conceptual design of a new burner to cope with different fuel mixtures for furnaces and temperature levels (to be used in preheating and also melting furnaces). The prototype of the new burner concept co-firing NG and syngas will be manufactured and tested for different shares of syngas in the gas mixtures reaching TRL 5-6.
- **The burners will operate in continuous regulation mode.**

8.2.4 Environment

The main URS-M&CS related to environment are: related to reduce the CO₂ emissions by improving current control.

	Document:	D6.1 User Requirements Specification for the MCS	
	Author:	Tecnalía	Version: 2
	Reference:	D6.1 VULKANO G.A. 723803	Date: 25/05/17

8.2.5 Safety

All the safety elements will be built and taken into strict consideration (i.e. safeguarding against overload, maximum temperature, etc.). In this sense, the same URS-M&CS described in section 8.1.5 will apply to the design and implementation of the M&CS in the VULKANO steel furnace.

8.2.6 Others

URS-M&CS related to other issues are:


- Diagnosis of the M&CS - control loops already implemented in the furnace to detect weaknesses that have to be solved by the new M&CS design.
- New M&CS improvements will be directly implemented in the M&CS of VSF.

8.2.7 Summary

A summary of Valji requirements specifications for monitoring and control systems explained in previous sections is shown in Table 6. The first column is “Section” that identifies the item that is associated. The second one is “M&CS-USR description” that shows a brief explanation of each requirement. The third one is “priority level” that identifies the importance for future implementation by clustered into three priority levels for implementation: High priority with red colour, medium priority with orange colour and Low priority with yellow colour.

Table 6. VSF - Summary of M&CS-USR

SUMMARY OF URS-M&CS (VSF, VALJI)				
Section		M&CS-USR and description		Priority level
1	Raw materials flow	1	Monitor and control inlet and output air stream and the percentage of oxygen carried.	Medium
		2	Monitor and control flow gas to combustion.	Medium
		3	Monitor the load exposed to heat treatment	Low
2	Equipment and sensors	1	Regulation will be made by PLC. Equipment for controlling and regulation of the furnace will be placed in two main electric cabinets near the furnace. Communicational panel will be situated on the forefront of the main electric control cabinet, which is connected to the PLC.	Medium
		2	For the actuators, gas equipment and burners, pneumatics and electric drives will be considered.	Medium
		3	For control and regulation, power inverters and electrical equipment and PLC platform of Siemens (SIMATIC) will be considered.	Medium

	Document:	D6.1 User Requirements Specification for the MCS	
	Author:	Tecnalía	Version: 2
	Reference:	D6.1 VULKANO G.A. 723803	Date: 25/05/17

		4	New equipment and sensors are listed in Table 6.4. The measuring equipment proposed is the traditional one in these kinds of furnaces: pressure (relative, absolute and differential), temperature at different zones of the furnace, gas flowmeter, air/fuel ratio and end positions measures.	Medium ²
3	Energy efficiency	1	Simulation of the solution for the integration of the PCM recovery system.	High
		2	Monitoring, measurement and controlling co-firing of natural gas and syngas.	High
		3	The burners will operate in continuous regulation mode.	Medium
4	Environment	1	Reduce the CO2 emissions by improving current control.	Low
5	Safety	1	In order to: 1) facilitate the future CE marking and 2) avoid potential economic costs associated with future re-adaptations or modifications needed to ensure compliance with MD, the design and implementation of M&CS improvements will be aligned with EHSR of MD. General safety requirements for the reduction of risks associated with VSF will be conducted with ISO 13577. In particular, safety requirements related to M&CS parts (hardware and software) that are assigned to provide safety functions (safety-related parts of control systems, SRP/CS) will take ISO 13577-4 part into account. Additional SRP/CS requirements not fully covered by this standard will be conducted according to standards listed in section 3 of this document.	High
6	Other	1	Diagnosis of the M&CS - control loops already implemented in the furnace to detect weaknesses that have to be solved by the new M&CS design.	Medium
		2	New M&CS improvements will be directly implemented in the M&CS of VSF.	Medium

Although the M&CS-USR in red colour are selected to develop the future functional design specification for M&CS in industrial furnaces (Task 6.2 and corresponding deliverable D6.2), the other M&CS-USR in orange and yellow colours will be also developed but not deeply.

Due to public dissemination of this deliverable, its content has been limited to maintain the confidentiality required by the end users. A greater detail of selected M&CSs of melting furnace of Bosio–Valji use case will show in deliverable D6.2 due to confidential dissemination, only for members of the consortium.

² VSF: The final list of new equipment & sensors will be specified in D6.2 “Functional design specification for MCS in industrial furnaces”.

	Document:	D6.1 User Requirements Specification for the MCS		
	Author:	Tecnia	Version:	2
	Reference:	D6.1 VULKANO G.A. 723803	Date:	25/05/17

9 IMPACT OVER SPIRE ROADMAP

One of the SPIRE ambitions is to reduce fossil energy intensity up to 30%. The aim is that introducing new monitoring and modelling techniques, processes and energy recovery might achieve higher efficiency levels. This report represents a state of the art for several technologies present in furnace monitoring and control, therefore moving to novel control techniques that use more sophisticated monitoring systems and newer refractory materials, the whole furnace efficiency should be increased.

One of the recommendations from SPIRE is to develop energy efficient solutions from a multi sectorial point of view. This deliverable aims at describing considerations on control techniques when integrating innovative solutions in industrial furnaces towards a more energy efficiency behaviour, attending to different criteria I) from different sectors (aluminium, steel and ceramic) and ii) different retrofitting solutions (refractory materials, new burners using syngas, PCMs, predictive tool).

	Document:	D6.1 User Requirements Specification for the MCS		
	Author:	Tecnalía	Version:	2
	Reference:	D6.1 VULKANO G.A. 723803	Date:	25/05/17

10 CONCLUSIONS

This deliverable reviews various types of instrumentation technologies used in industrial furnaces. Advantages and disadvantages depending on operational conditions are described, such as the best appropriate temperature sensors in dirty atmospheres.

Industrial furnaces modelled as an equivalent thermal circuit is shown by using Kirchhoff laws. This methodology of modelling thermal system is useful to perform simulation when controller needs to be parametrized.

A brief review of designing controllers for industrial furnaces is included, and using different approaches: i) Classical theory of control system that normally deals with single input single output to regulate setpoints; ii) modern control theory and robust control that deals with Nonlinear Multi-Input-Multi-Output systems.

Some challenges identified on scientific bibliography are addressed and structured into: Phase Change Materials (PCMs) to energy recovery, advanced materials for refractories purposes; burners co-firing natural gas and syngas; new strategies of Monitoring and Control System.

Lesson learned on M&CSs by industrial VULKANO partners (Toreccid, -Valji and ASAS) are addressed into: Steel sector focus on preheating, ceramic sector focus on melting process, and aluminium sector focus on heating and melting. The information is gathered by a questionnaire sent by email to industrial partners.


Description of two main use cases (Torrecid and Valji) is provided. These descriptions are structured into: technical characteristics, process description; control and issues will be development on VULKANO project.

Although two main URS-M&CS priorities have been identified in the VULKANO ceramic furnace (VCF), the rest of items identified will be taken into account. The first priority is directly related to the implementation of a project development the **PCM recovery system**. The second one addresses the **measurement and monitoring of the external furnace temperature**.


With regards to the VULKANO steel furnace (VSF), two main URS-M&CS priorities directly connected to the implementation of VULKANO developments have been also identified: i) the **co-firing of NG and syngas** and ii) the **PCM recovery system at designing level since it is not going to be implemented in the demo site**.

In both cases – VCF and VSF - **safety issues related to those M&CS parts** (hardware and software) that are assigned to provide safety functions (safety-related parts of control systems, SRP/CS) have been also considered.

Table 5 and Table 6 will be used as a fundamental input for task T6.2 and D6.2, where final URS-M&CS for VIF will be selected and specified for their implementation in case studies.


	Document:	D6.1 User Requirements Specification for the MCS		
	Author:	Tecnia	Version:	2
	Reference:	D6.1 VULKANO G.A. 723803	Date:	25/05/17

Finally, concerning the connections between VIF-M&CS and the tool to be developed in WP7 (Holistic In-House Predictive Tool), the deliverable D6.2 will provide M&CS - specifications to ensure a proper design and operation of the tool (e.g. signals to be captured, sensors, data formats, etc.).


	Document:	D6.1 User Requirements Specification for the MCS	
	Author:	Tecnalía	Version: 2
	Reference:	D6.1 VULKANO G.A. 723803	Date: 25/05/17

11 REFERENCES

- Arthur, R.M., W.L. Straube, J.W. Trobaugh & E.G. Moros, 2005. Non-invasive estimation of hyperthermia temperatures with ultrasound. *International journal of hyperthermia : the official journal of European Society for Hyperthermic Oncology, North American Hyperthermia Group*, 21(6), 589-600.
- Brandt, M.J., K.M. Johnson, A.J. Elphinston & D.D. Ratnayaka, 2017. Chapter 18 - Valves and Meters, in *Twort's Water Supply (Seventh Edition)* Boston: Butterworth-Heinemann, 743-75.
- Braun, W., P. GebSKI, R. MacRosty, R. Pula, A. Sadri & W. Ying, 2016. Tap-hole monitoring technologies. *Journal of the Southern African Institute of Mining and Metallurgy*, 116(1), 1-9.
- Burrows, S.E., S.N. Ramadas, T.J.R. Eriksson, L. Kang, S.M. Dixon, A. Unger & M. Kupnik, 2016. High temperature flexural ultrasonic transducer for non-contact measurement applications, in *2016 Joint IEEE International Symposium on the Applications of Ferroelectrics, European Conference on Application of Polar Dielectrics, and Piezoelectric Force Microscopy Workshop (ISAF/ECAPD/PFM)*, 1-3.
- Campos, S.R.V., J.L. Baliño, I. Slobodcicov, D.F. Filho & E.F. Paz, 2014. Orifice plate meter field performance: Formulation and validation in multiphase flow conditions. *Experimental Thermal and Fluid Science*, 58, 93-104.
- Childs, P.R.N., 2001. 6 - Resistance temperature detectors, in *Practical Temperature Measurement* Oxford: Butterworth-Heinemann, 145-93.
- Fu, J., Z. Liu, S. Han, J. Zhao & Y. Huang, 2017. Comparison of temperature difference measurement technologies used in vehicular heat exchangers. *Experimental Thermal and Fluid Science*, 82, 94-101.
- Fumagalli, L., M. Macchi, C. Colace, M. Rondi & A. Alfieri, 2016. A Smart Maintenance tool for a safe Electric Arc Furnace. *IFAC-PapersOnLine*, 49(31), 19-24.
- Glassman, I. & R.A. Yetter, 2008. Chapter 4 - Flame Phenomena in Premixed Combustible Gases, in *Combustion (Fourth Edition)* Burlington: Academic Press, 147-260.
- González-González, A., I. Etxeberria-Agiriano, E. Zulueta, F. Oterino-Echavarri & J. Lopez-Guede, 2014. Pitch Based Wind Turbine Intelligent Speed Setpoint Adjustment Algorithms. *Energies*, 7(6), 3793-809.
- Honner, M., Z. Vesely & M. Svantner, 2003. Temperature and heat transfer measurement in continuous reheating furnaces. *Scandinavian Journal of Metallurgy*, 32(5), 225-32.
- Horowitz, I.M. & M. Sidi, 1972. Synthesis of feedback systems with large plant ignorance for prescribed time-domain tolerances†. *International Journal of Control*, 16(2), 287-309.
- Hu, Y., C.K. Tan, J. Broughton & P.A. Roach, 2016. Development of a first-principles hybrid model for large-scale reheating furnaces. *Applied Energy*, 173, 555-66.
- Ihara, I. & M. Takahashi, 2007. A New Method for Internal Temperature Profile Measurement by Ultrasound, in *2007 IEEE Instrumentation & Measurement Technology Conference IMTC 2007*, 1-5.
- Jebavá, M., P. Dyrčíková & L. Němec, 2015. Modelling of the controlled melt flow in a glass melting space — Its melting performance and heat losses. *Journal of Non-Crystalline Solids*, 430, 52-63.

	Document:	D6.1 User Requirements Specification for the MCS	
	Author:	Tecnalia	Version: 2
	Reference:	D6.1 VULKANO G.A. 723803	Date: 25/05/17

- Li, W., G. Lin & B. Li, 2016. Inverse regression-based uncertainty quantification algorithms for high-dimensional models: Theory and practice. *Journal of Computational Physics*, 321, 259-78.
- Lowe, D., G. Machin & M. Sadli, 2015. Correction of temperature errors due to the unknown effect of window transmission on ratio pyrometers using an in situ calibration standard. *Measurement*, 68, 16-21.
- Martínez, D.S., F. Illán, J.P. Solano & A. Viedma, 2017. Embedded thermocouple wall temperature measurement technique for scraped surface heat exchangers. *Applied Thermal Engineering*, 114, 793-801.
- Montalvo, C., A. García-Berrocal, J.A. Bermejo & C. Queral, 2014. Advanced surveillance of Resistance Temperature Detectors in Nuclear Power Plants. *Annals of Nuclear Energy*, 65, 35-40.
- Nardin, G., A. Meneghetti, F. Dal Magro & N. Benedetti, 2014. PCM-based energy recovery from electric arc furnaces. *Applied Energy*, 136, 947-55.
- Ojasvi, A.K. & N. Kaistha, 2016. Control System Design for Furnaces With Multiple Parallel Passes. *IFAC-PapersOnLine*, 49(7), 741-6.
- Olivieri, E., M. Rotter, M. De Combarieu, P. Forget, C. Marrache-Kikuchi & P. Pari, 2015. Full range resistive thermometers. *Cryogenics*, 72, Part 2, 148-52.
- Pang, M., L. Shu, J. Lu, X. Zhu & J. Rodrigues, 2013. A case study: Monitoring heat exchanger based on vibration sensors and nondestructive testing technique, in *2013 8th International Conference on Communications and Networking in China (CHINACOM)*, 511-6.
- Pirouzpanah, S., M. Çevik & G.L. Morrison, 2014. Multiphase flow measurements using coupled slotted orifice plate and swirl flow meter. *Flow Measurement and Instrumentation*, 40, 157-61.
- Sadri, A., W. Ying, J. Erskine & R. Macrosty, 2016. Smelting furnace Non-Destructive Testing (NDT) and monitoring, in *19th World Conference on Non-Destructive Testing*.
- Saranya, S.N., V.M. Sivakumar, M. Thirumarimurugan & G.C. Sowparnika, 2017. Modeling and control of plate type heat exchangers using PI and PID controllers, in *2017 11th International Conference on Intelligent Systems and Control (ISCO)*, 439-43.
- Sun, D., G. Lu, H. Zhou, Y. Yan & S. Liu, 2015. Quantitative assessment of flame stability through image processing and spectral analysis. *IEEE Transactions on Instrumentation and Measurement*, 64(12), 3323-33.
- Upton, C., F. Quilligan, C. Garc a-Santiago & A. Gonz lez-Gonz lez, 2013. Energy Efficient Production Planning, in *IFIP Advances in Information and Communication Technology*, 88-95.
- Valliappan, P., K. Jagiełło & S. Wilcox, 2012. The Monitoring and Control of Burners Co-Firing Coal and Biomass, in *ASME 2012 International Design Engineering Technical Conferences and Computers and Information in Engineering Conference* American Society of Mechanical Engineers, 139-49.
- Valliappan, P., S. Wilcox, K. Jagiełło & Y. Shao, 2016. Optimization of Co-Firing Burners. *Journal of Thermal Science and Engineering Applications*, 8(4), 041001.
- Wang, Y.W.A., T. Hazel, R. Hjørnevik & F. Ø, 2015. Equipment monitoring for temperature related failures using thermography cameras, in *2015 IEEE Petroleum and Chemical Industry Committee Conference (PCIC)*, 1-9.
- Wei, D., S. You-An, S. Bi-Nan, G. Ye-Wei, D. Yan-Xia & X. Guang-Ming, 2017. Reconstruction of internal temperature distributions in heat materials by ultrasonic measurements. *Applied Thermal Engineering*, 112, 38-44.

	Document:	D6.1 User Requirements Specification for the MCS		
	Author:	Tecnalia	Version:	2
	Reference:	D6.1 VULKANO G.A. 723803	Date:	25/05/17

- Yin, C. & J. Yan, 2016. Oxy-fuel combustion of pulverized fuels: Combustion fundamentals and modeling. *Applied Energy*, 162, 742-62.
- Zalba, B., J.M. Marín, L.F. Cabeza & H. Mehling, 2003. Review on thermal energy storage with phase change: materials, heat transfer analysis and applications. *Applied Thermal Engineering*, 23(3), 251-83.
- Zareba, S., A. Wolff & M. Jelali, 2016. Mathematical modelling and parameter identification of a stainless steel annealing furnace. *Simulation Modelling Practice and Theory*, 60, 15-39.
- Zhengbing, H., V. Jotsov, S. Jun, O. Kochan, M. Mykyichuk, R. Kochan & T. Sasiuk, 2016. Data science applications to improve accuracy of thermocouples, in *2016 IEEE 8th International Conference on Intelligent Systems (IS)*, 180-8.
- Zuzunaga, A. & B. Maron, 2013. A survey of non-invasive and semi-invasive flow meters for mining applications: Understanding and selecting the right technology for the application. *CiDRA Minerals Processing, Wallingford, USA*.
- Švantner, M., P. Vacíková & M. Honner, 2013. Non-contact charge temperature measurement on industrial continuous furnaces and steel charge emissivity analysis. *Infrared Physics & Technology*, 61, 20-6.
- www.engineeringtoolbox.com